



GRANADA COMMUNITY SERVICES DISTRICT

**AGENDA**  
**BOARD OF DIRECTORS**  
**REGULAR MEETING at 7:30 p.m.**

Thursday, August 17, 2023

**NOTICE PERTAINING TO PUBLIC ACCESS TO THE MEETING**

The Board of Directors' meeting room is open to the public during open session. To maximize public access to public meetings, the Granada Community Services District staff and board members will be generally be participating in person at the board meeting, as well as using videoconference to allow remote participation by members of the public, board members, and staff as necessary. Members of the public may participate via ZOOM online or by telephone using the link below.

**Zoom information below:**

<p><b>Topic: GCSD Board Meeting</b> <b>Time: Aug 17, 2023 07:30 PM Pacific</b> <b>Time (US and Canada)</b></p> <p>Join Zoom Meeting <a href="https://us02web.zoom.us/j/82642686214">https://us02web.zoom.us/j/82642686214</a></p> <p>Meeting ID: 826 4268 6214</p>	<p><b>OR</b></p> <p>Dial by your location +1 669 444 9171 US</p>
--	--

**CALL REGULAR MEETING TO ORDER AT 7:30 p.m.**

District Office Meeting Room, 504 Avenue Alhambra, 3rd Floor, El Granada.

**ROLL CALL**

Directors:	President:	Nancy Marsh
	Vice-President	Jen Randle
	Director:	Matthew Clark
	Director:	Barbara Dye
	Director:	Jill Grant

Director Grant will be participating remotely via teleconference pursuant to Government Code Section 54953(b) from 128 Coronado St., El Granada.

Staff:	General Manager:	Chuck Duffy
	Assistant Manager:	Hope Atmore
	Legal Counsel:	William Parkin

The Board has the right to take action on any of the items listed on the Agenda. The Board reserves the right to change the order of the agenda items, to postpone agenda items to a later date, or to table items indefinitely.

### **GENERAL PUBLIC PARTICIPATION**

Public members may comment on matters under the jurisdiction of the District that are not on the agenda. Comments are limited to 3 minutes. See the instructions above to comment via ZOOM (online) or by telephone.

### **REGULAR MEETING AGENDA**

- 1. Parks and Recreation Activities.**
  - a. Report on Granada Community Park and Recreation Center.
  - b. Review of planned Recreation Program events.
- 2. Consideration of Approval of Class 3 Mainline Extension Permit for Neal and Inga Solloway, 1230 Columbus Street, El Granada.**

**Recommendation:** Approve the Class 3 Mainline Extension Permit.
- 3. Resolution to Authorize District Staff to Participate in State Disability Insurance Program.**

**Recommendation:** Approve the Resolution.
- 4. Consideration of Directors Compensation.**
- 5. Consideration of Revised Starting Time for District Regular Board Meetings.**
- 6. Consideration of District Letter of Support for the Midcoast Community Council's request to San Mateo County to Fund Planning for Community Broadband.**
- 7. Engineer's Report.**
- 8. Report on Sewer Authority Mid-Coastside Meetings.**

### **CONSENT AGENDA**

- 9. July 20, 2023 Regular Meeting Minutes.**
- 10. August 2023 Warrants.**
- 11. June 2023 Financial Statements.**
- 12. Assessment District Distribution #2-23/24.**

### **COMMITTEE REPORTS**

- 13. Report on seminars, conferences, or committee meetings.**

### **INFORMATION CALENDAR**

- 14. Attorney's Report. (Parkin)**
- 15. General Manager's Report. (Duffy)**
- 16. Administrative Staff Report. (Atmore)**
- 17. Future Agenda Items.**

**ADJOURN REGULAR MEETING**

At the conclusion of the July 20, 2023 Meeting:

Last Ordinance adopted: No. 175

Last Resolution adopted: No. 2023-10

This meeting is accessible to people with disabilities. If you have a disability and require special assistance related to participating in this teleconference meeting, please contact the District at least two working days in advance of the meeting.

Except for records exempt from disclosure under section 6254 of the Public Records Act, all materials distributed to the Board for the Agenda are disclosable to the public upon request. Please contact Nora Mayen at (650) 726-7093 or via email at [gcsdadmin@granada.ca.gov](mailto:gcsdadmin@granada.ca.gov) to request assistance with either of these issues.

Blank



**ITEM #1**



GRANADA COMMUNITY SERVICES DISTRICT

---

---

AGENDA MEMORANDUM

---

---

To: Board of Directors  
From: Hope Atmore, Assistant General Manager  
Subject: Parks and Recreation Activities  
Date: August 17, 2023

---

**Granada Community Park and Recreation Center**

Staff met with members of the San Mateo County Planning Department regarding possible NOAA Climate Resilience Funding. This funding opportunity is very preliminary and SMC Planning Department Staff are developing a list of interested parties including special districts. This funding is focused on collaborative efforts to address resilience in coastal communities across the country.

**Recreation Programs**

By request of the District Board, staff will market the following tentative schedule of events:

- Ramp Jam to benefit ALAS through HeartDrive Collective 8/19/23, 2:00-8:00PM
- Nature Walk with GCSD Board Members 8/26/23, 11:00AM-12:00PM
- History Walk with GCSD Board Members 9/17/23, 10:00AM-11:00AM
- BORP Bike Outing, 9/22/23, 10:00AM (older adults) / 1:00PM (EG Elementary students)
- Movie in the Park w/ Beach Break Entertainment – *Jumanji, Welcome to the Jungle* 9/30/23, half hour after sunset
- Ramp Jam to benefit ALAS through HeartDrive Collective 10/7/23, 2:00-8:00PM
- Coastside Land Trust Nature Journaling (date and time TBD / October)
- Hike with Golden Gate National Parks Conservancy (date and time TBD / October)

Other possible ideas for board consideration:

- Halloween event with Cove Collective or businesses in the Harbor
- Additional movie in the Park – Halloween themed

Blank

## **ITEM #2**



GRANADA COMMUNITY SERVICES DISTRICT

---

## AGENDA MEMORANDUM

---

To: Board of Directors  
From: Hope Atmore, Assistant General Manager  
Subject: Consideration of Class 3 Mainline Extension Permit to Serve  
APN 047-288-030, with Associated Grant of Easement to the District  
Date: August 17, 2023

---

This item is for consideration to approve a Class 3 Mainline Extension Sewer Permit to serve one lot, with the associated grant of easement to the District. The Class 3 permit application was submitted on 7/31/2023 by the owners of the lot, Neal and Inga Solloway. The District Engineer has reviewed and approved the construction plans for the extension. The parcel is currently connected to the sewer mainline in Francisco Street with a private lateral that runs through the full length of an adjacent parcel (APN 047-288-160) on a private easement. For the benefit of the applicant and the neighboring parcel, the District recommends the approval of an extension of the existing mainline that runs from Santa Maria Avenue across a district easement through APN 047-288-250 to the applicant's property. The extension will require a concurrent quitclaim of the current district easement on parcel 047-288-250 along with a new easement for the new mainline, as well as a new easement on the applicant's property.

The following documents are attached for your consideration of this item:

- Assessor's Parcel Map with existing mainlines, existing lateral, and new mainline
- Engineer's letter
- Permit Application
- Sewer main plans
- Solloway Easement
- Pollard quitclaim form
- Pollard Easement

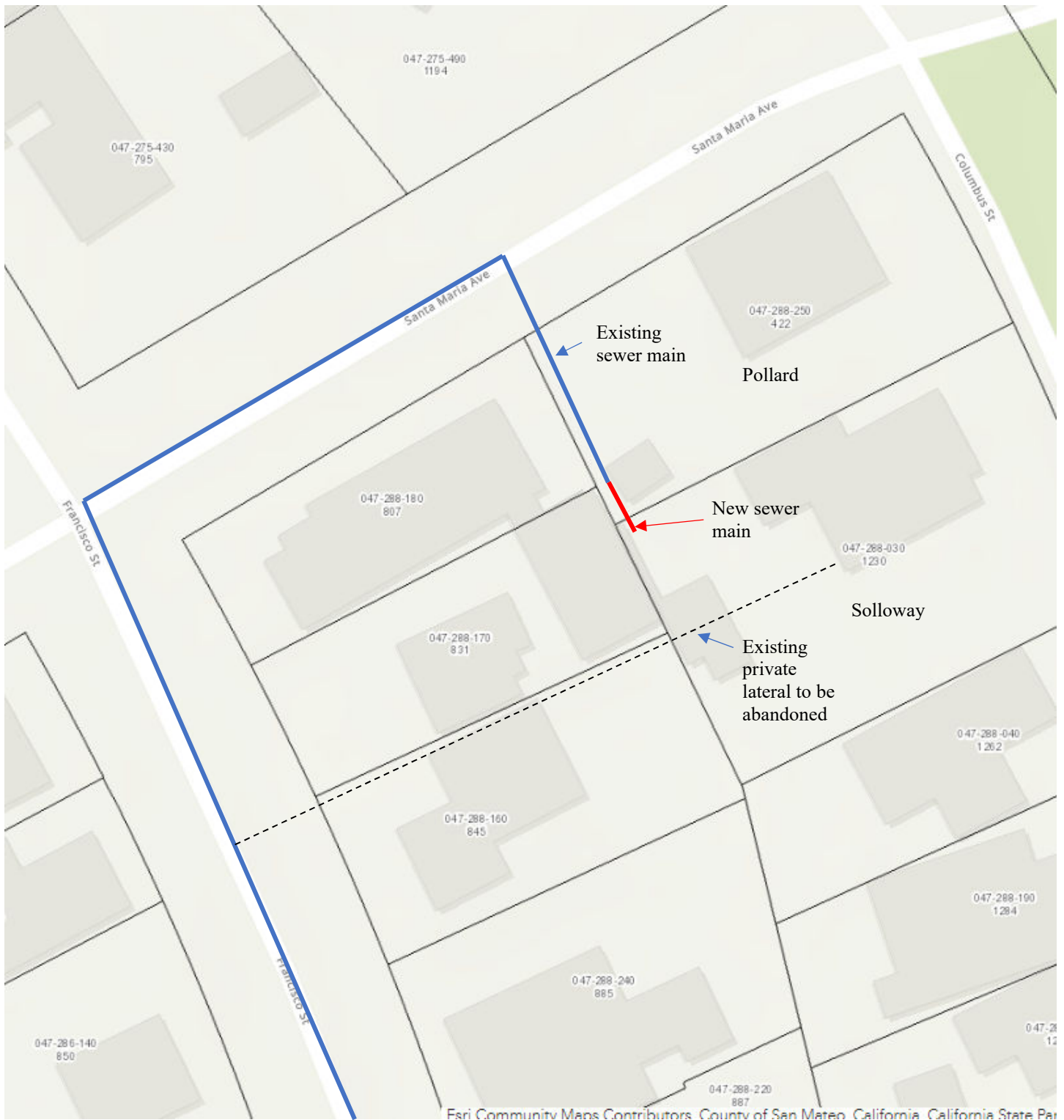

Esri Community Maps Contributors, County of San Mateo, California, California State Pa



## Hope Atmore

---

**From:** John Rayner <JohnRayner@kennedyjenks.com>  
**Sent:** Tuesday, August 1, 2023 6:17 PM  
**To:** Hope Atmore; Chuck Duffy; Xiangquan Li  
**Cc:** Delia Comito  
**Subject:** RE: Salloway - 047-880-030 Class 3 Mainline extension  
**Attachments:** Solloway Existing Lat to Rayner.pdf

Hi Hope & Delia,

The information provided in your emails is sufficient to get started on processing an extension of the existing mainline and its easement on the Pollard parcel. As shown on the attachment, the 6" mainline extension and its associated easement will have to include the portion of the mainline and its terminal cleanout (designated as a lamphole on the attachment) on the Solloway parcel. It appears that the Solloway easement will extend only about 8' onto the Solloway parcel.

I recommend that GCSD proceed processing this Class 3 mainline extension and the associated easements. Please let me know if you have any questions. Thanks.

John

---

**From:** Hope Atmore <hatmore@granada.ca.gov>  
**Sent:** Tuesday, August 1, 2023 5:20 PM  
**To:** John Rayner <JohnRayner@kennedyjenks.com>; Chuck Duffy <cduffy@dudek.com>; Xiangquan Li <XiangquanLi@kennedyjenks.com>  
**Cc:** Delia Comito <dcomito@granada.ca.gov>  
**Subject:** Salloway - 047-880-030 Class 3 Mainline extension

### EXTERNAL EMAIL

**This email includes an ATTACHMENT from outside of KJ and could contain malicious links.**

Ensure email is from a **trusted** sender before opening the attachment.

Never enter your login credentials if prompted. Contact **IST** if you have any questions.

Hello John,

Attached is the application, the plan (existing lateral is shown in green, red is the proposed), the easement that Delia put together, and the assessor map of the property.

Sorry to have this all on your plate right before you leave on your trip. Hopefully, this looks clear enough to move forward.

Hope

*CONFIDENTIALITY NOTICE - This message is intended only for the use of the individual or entity to which it is addressed and may contain information that is privileged, confidential or exempt from disclosure under applicable law. If the reader of this message is not the intended recipient, or the employee or agent responsible for delivering the message to the intended recipient, you are hereby notified that any dissemination, distribution, or copying of this communication is strictly prohibited, and we request that you destroy or permanently delete this message, and notify the sender.*

SEWER PERMIT APPLICATION

**Parcel** Assessor's Parcel Number(s): 047-288-250 Lot(s): 27+28 Block: 288

**Data:** Address/Location: 1230 Columbus st El Granada

**Owner:** Name(s) Neal & Inga Solloway Phone #: 650-726-6419  
Address: P.O. Box 125 El Granada CA Cell #: 650-678-8036  
Email Address: nealsolloway@yahoo.com

**Agent:** Name(s) Sigwa Prime Geo, Phone #: 650-728-3590  
Address: BGT Surveyors - Cell #: 650-212-1030  
Email Address: \_\_\_\_\_

**Contractor:** Name Dave Mossa Email Address: \_\_\_\_\_  
Address: P.O. Box 370688 Monterey CA 94037 Cell #: 650-868-9673

**Project Type:** (Check one)  
New Construction \_\_\_\_\_ Remodel/Addition \_\_\_\_\_ Demolition \_\_\_\_\_ Mainline Ext. X

**Project Description:** (Check all that apply)  
Single Family Dwelling  Multiple Family Residential \_\_\_\_\_  
Auxiliary Dwelling Unit (ADU) \_\_\_\_\_ Hotel/Motel, Condo, or B&B \_\_\_\_\_  
Commercial Building or Warehouse \_\_\_\_\_ Mixed Use (Commercial & Residential) \_\_\_\_\_  
Other  Explain: Extend main - Replace lateral

**General Information:** (Complete applicable sections)  
Parcel Sq. Ft.: 12500 Total Living Area Sq. Ft.: 1370 Garage Sq. Ft.: 780±  
No. of Bedrooms: 2 No. of Baths: 2 No. of Offices: 1 No. of Living Units: 1  
If more than one living unit, list sq. ft. for each: \_\_\_\_\_  
No. of Trees to be Removed: 0 Is tree removal for lateral placement? \_\_\_\_\_  
Additional Comments: Existing lateral leaking

- In consideration of granting this permit, the undersigned agrees:
- To accept and abide by all provisions of the District Code.
  - To leave trench open and notify the District when sewer is ready for connection to the sewer main line.
  - In the event that all required planning approvals are not final, the application shall be deemed incomplete, and any permit issued may be revoked.
  - To provide the District with the final Building Plans for this project if requested, prior to permit issuance.

**Signature:** Neal Solloway Print Name: Neal Solloway Date: 7/31/2023

FOR DISTRICT USE ONLY (Please do not write below this line)

<input type="checkbox"/> Planning Approval Letter	<input type="checkbox"/> Pick up Notice	<input type="checkbox"/> Print Assessor's Map
<input type="checkbox"/> Grant Deed/Legal Description	<input type="checkbox"/> Is Application Complete?	<input type="checkbox"/> Print ML Map
<input checked="" type="checkbox"/> Plans/Elevations	<input type="checkbox"/> Is there a ML to serve?	____ Asmts. on parcel
<input checked="" type="checkbox"/> Plumbing Plans showing Sewer	<input type="checkbox"/> Print Asmt. Verification	____ Asmts. needed
<input type="checkbox"/> Topographical Map	Zoning Dist.: _____	Received on: <u>8/1/23</u>
<input type="checkbox"/> Agent Form	Application Fee \$ <u>150.00</u>	By: _____ (Date)



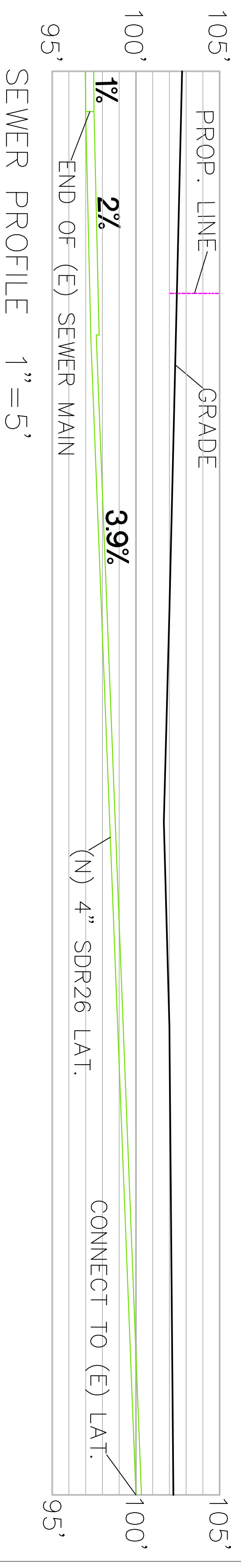
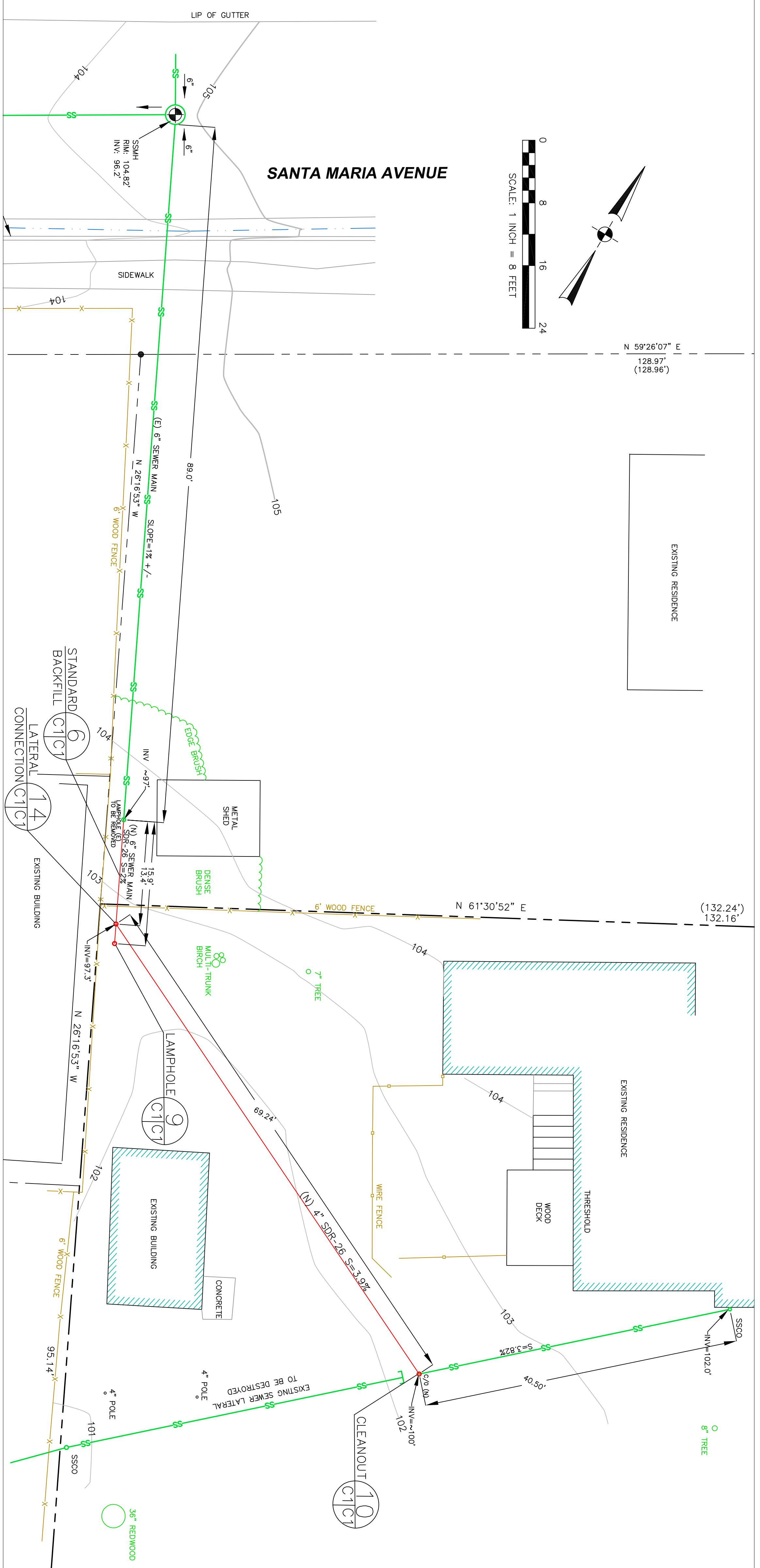
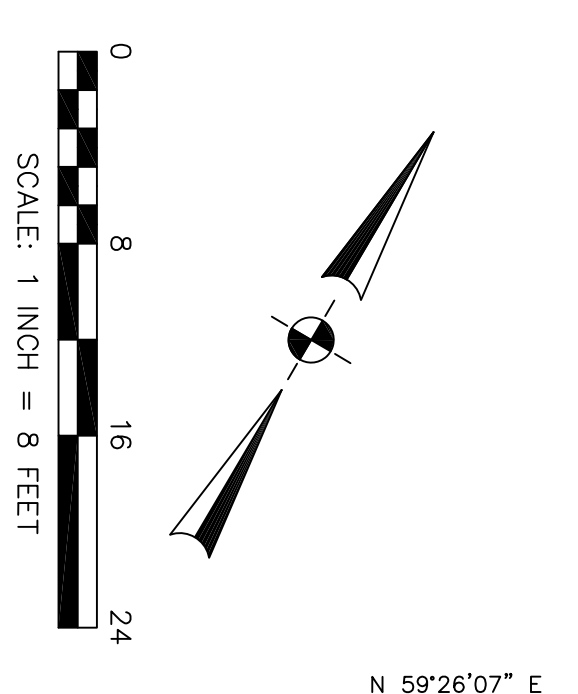

**LEGEND**

- EXISTING CONTOURS
- EXISTING
- N NEW, OR PROPOSED
- VIF VERIFY IN FIELD
- INV INVERT
- SSMH SANITARY SEWER MANHOLE

**GENERAL NOTES**

1. PLANS PREPARED AT REQUEST OF: NEAL SOLLOWAY, OWNER.
2. ELEVATION DATUM: NAVD83.
3. SITE SURVEYED BY BGL LAND SURVEYING, SURVEYED 5-9-23.
4. THIS IS NOT A BOUNDARY SURVEY.

**UTILITY NOTES**

1. INSTALLATION SHALL BE IN ACCORDANCE WITH GSD CODE AND STANDARD SPECIFICATIONS AND THE COUNTY OF SAN MATEO BUILDING DEPARTMENT.
2. NOTIFY USA AT 811 AT LEAST 48 HOURS PRIOR TO SITE WORK TO IDENTIFY LOCATION OF UNDERGROUND UTILITIES. CALL GSD ENGINEER AT LEAST 72 HOURS PRIOR TO SITE WORK TO SCHEDULE INSPECTIONS.

**SECTION AND DETAIL CONVENTION**

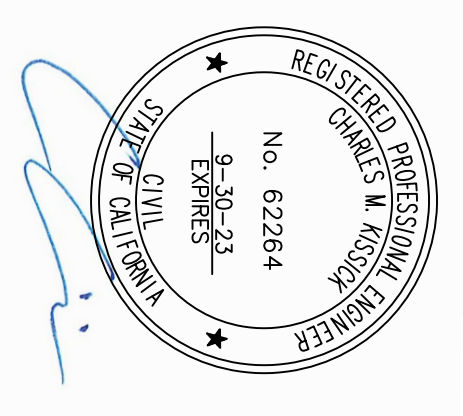
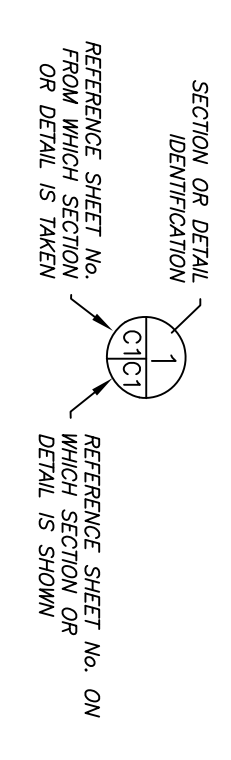

DATE:	8-1-23
DRAWN BY:	AZG
CHECKED BY:	CMK
REV. DATE:	
REV. DATE:	
PROJECT #:	23-152

**Sigma Prime Geosciences, Inc.**  
 SIGMA PRIME GEOSCIENCES, INC.  
 332 PRINCETON AVENUE  
 HALF MOON BAY, CA 94019  
 (650) 728-3590  
 SIGMAPRM@GMAIL.COM

**SANITARY SEWER PLAN**  
 SOLLOWAY PROPERTY  
 1230 COLUMBUS STREET  
 EL GRANADA  
 APN 047-880-030

**SHEET**  
**C-1**

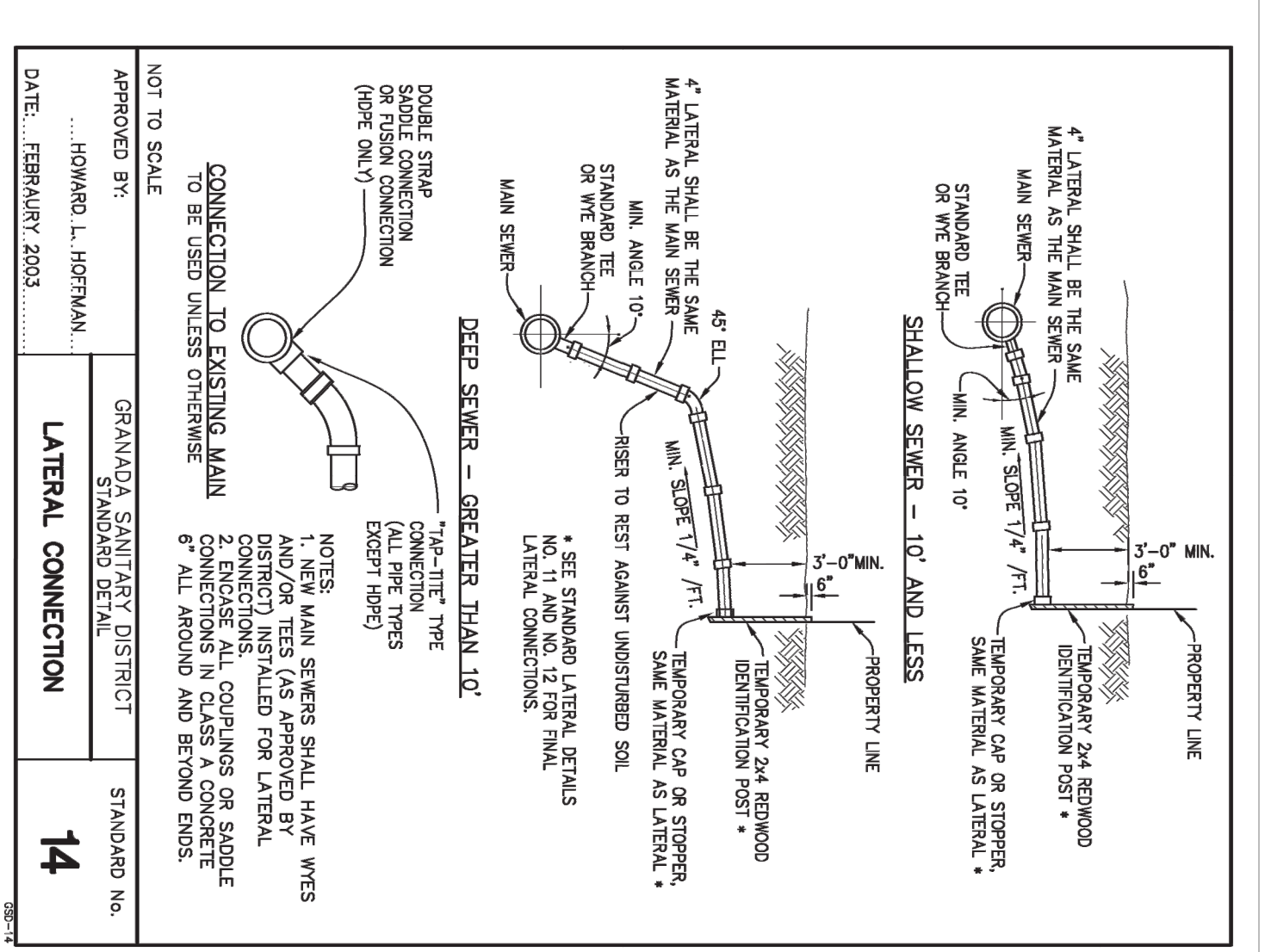
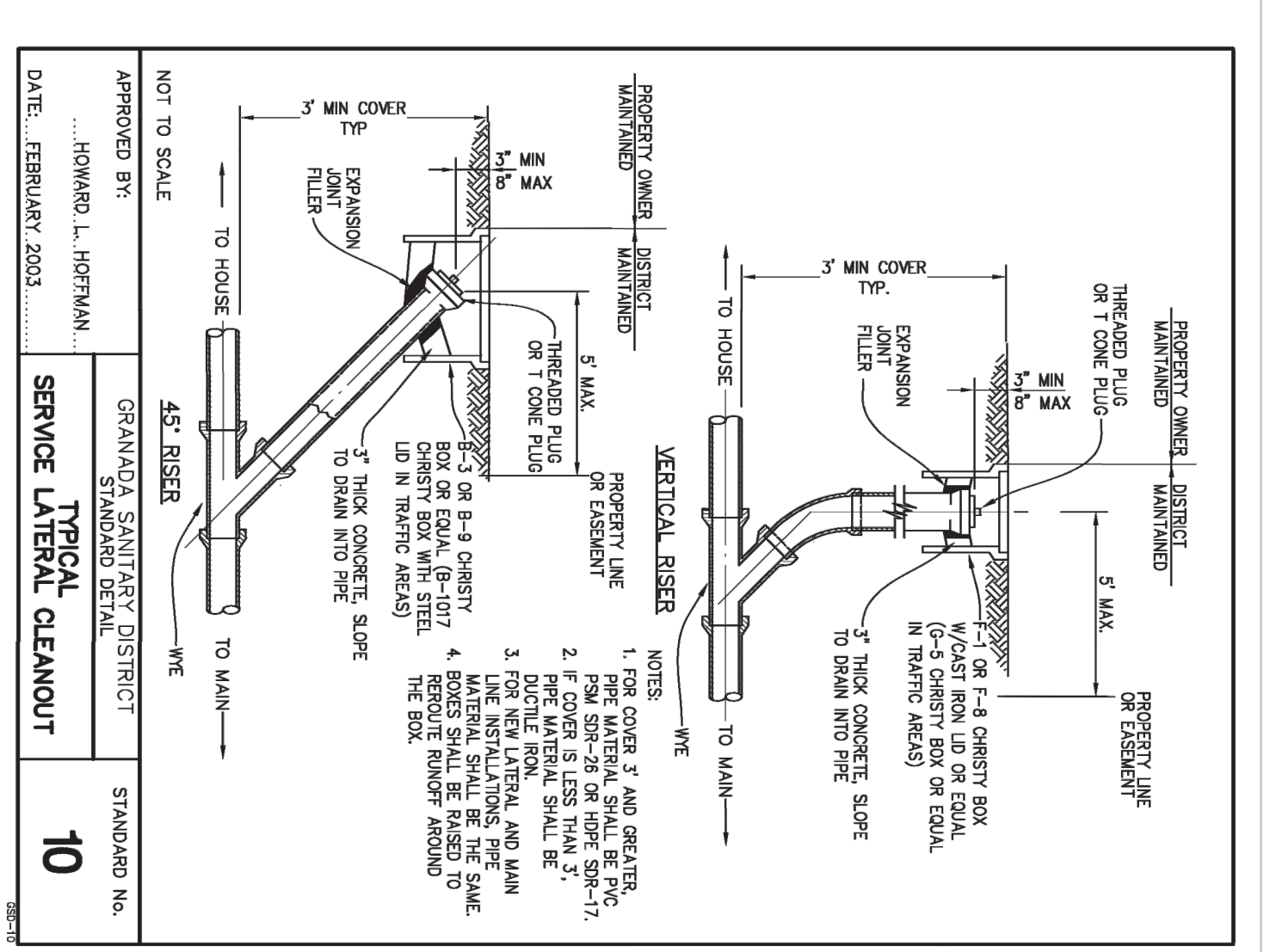
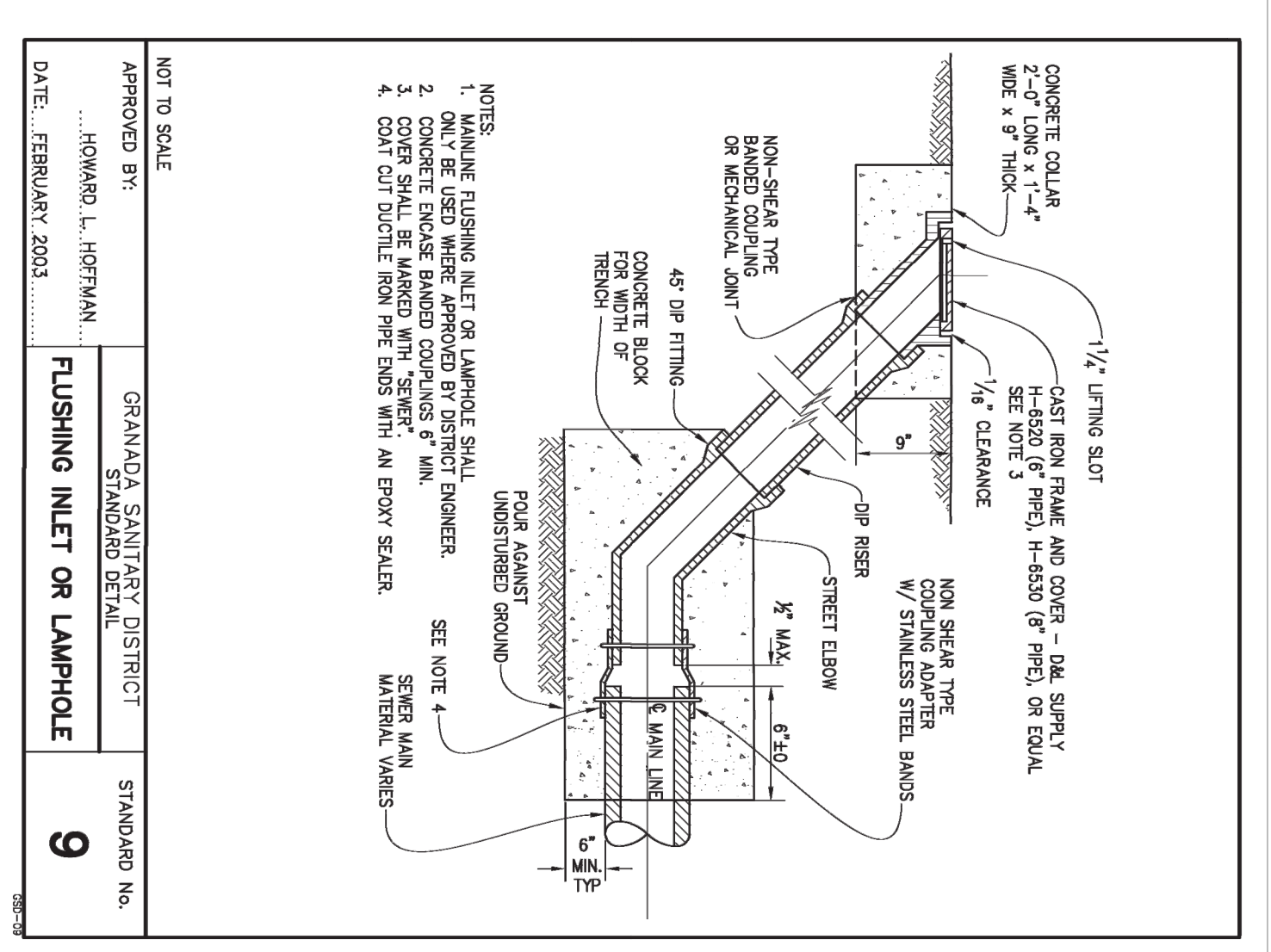
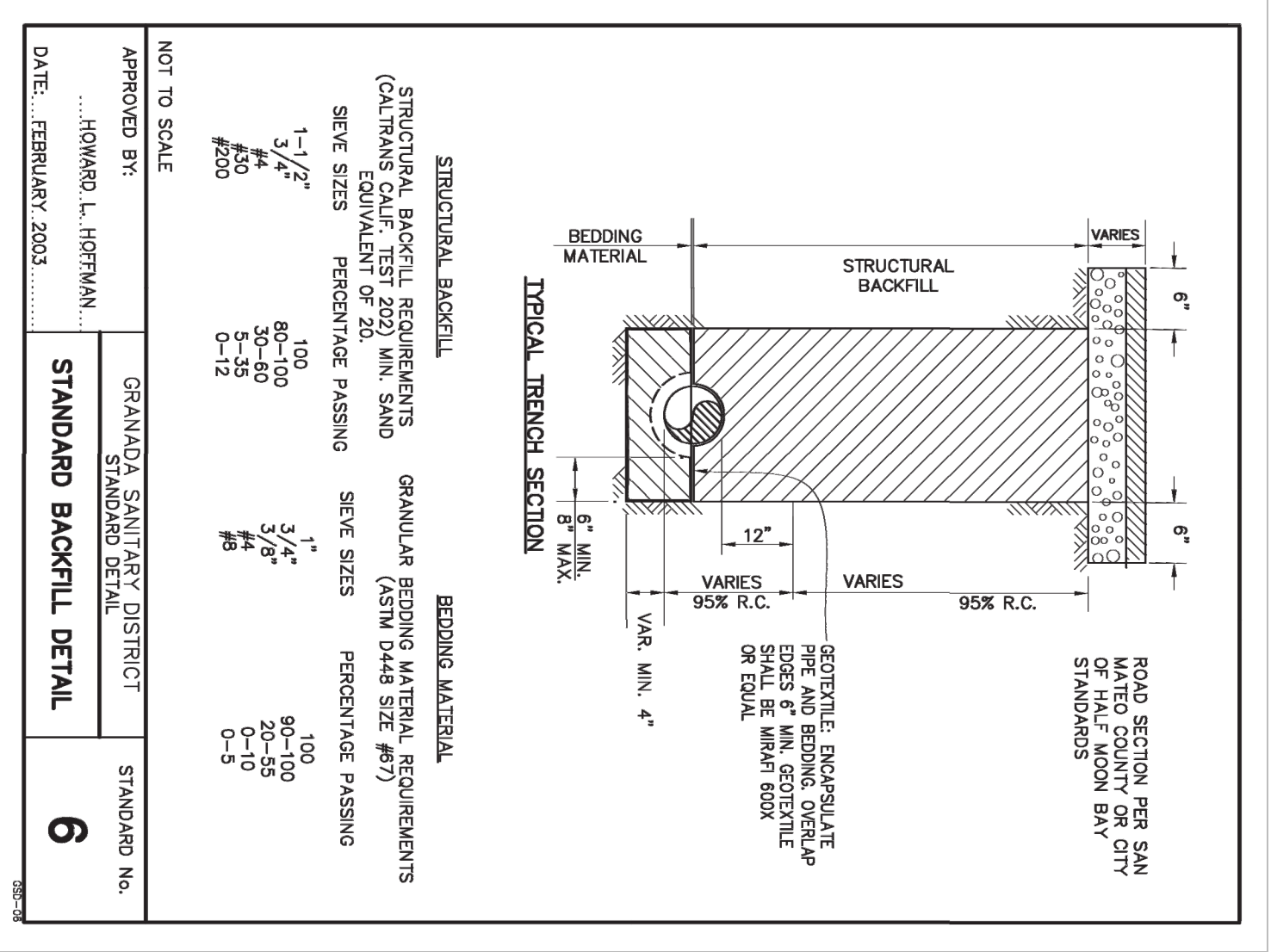

NOT TO SCALE  
 APPROVED BY: HOWARD L. HOFFMAN  
 GRANADA SANITARY DISTRICT  
 STANDARD DETAIL  
**6**

NOT TO SCALE  
 APPROVED BY: HOWARD L. HOFFMAN  
 GRANADA SANITARY DISTRICT  
 STANDARD DETAIL  
**9**

NOT TO SCALE  
 APPROVED BY: HOWARD L. HOFFMAN  
 GRANADA SANITARY DISTRICT  
 STANDARD DETAIL  
**10**

NOT TO SCALE  
 APPROVED BY: HOWARD L. HOFFMAN  
 GRANADA SANITARY DISTRICT  
 STANDARD DETAIL  
**14**

**WHEN RECORDED, PLEASE MAIL  
THIS INSTRUMENT TO:**

Secretary, Board of Directors  
Granada Community Services District  
P.O. Box 335  
El Granada, CA 94018

**SPACE ABOVE FOR  
RECORDER'S USE ONLY**

**EASEMENT**

**NO TRANSFER TAX DUE**

**Sewer Main Line and Appurtenances**

Assessor's Parcel No.: 047-288-030

Project Name: Solloway Sewer Main Extension

**Neal and Inga Solloway**, hereinafter designated Grantor(s) and owner(s) of the hereinafter described lands, for valuable consideration, do(es) hereby GRANT and CONVEY to the **GRANADA COMMUNITY SERVICES DISTRICT**, herein designated Grantee, a perpetual easement and right-of-way upon, through, under, over and across the hereinafter described real property for the installation, construction, operation, maintenance, repair, replacement, and reconstruction of sewer pipe lines and/or mains, manholes, sewer lateral pipe lines, and all structures incidental thereto, together with the perpetual right to remove buildings, structures, trees, bushes, undergrowth, flowers, and any other obstructions interfering with the use of said easement and right-of-way by Grantee, its successors or assigns and in addition thereto, to remove soil and other materials within said easement and right-of-way and to use the same in such manner and at such locations as said Grantee may deem proper, needful or necessary in the construction, reconstruction and maintenance of said sewer lines or structures incidental thereto.

To have and to hold said easement and right-of-way unto itself and unto its successors and assigns forever.

The real property referred to herein and made subject to said easement and right-of-way by this grant is situated in the County of San Mateo, State of California, and is particularly described as follows:

SEE EXHIBIT "A" (LEGAL DESCRIPTION) AND EXHIBIT "B" (EASEMENT PLAT)  
ATTACHED HERETO AND MADE A PART HEREOF.

The Grantors may, at their own risk, use the surface of the above described real property in a manner that will not interfere with or be detrimental to the use of said easement and right-of-way by Grantee, its successors and assigns, provided no trees shall be planted or grown thereon.

The Grantors hereby covenant and agree for themselves, their heirs, successors and assigns, that there shall not be constructed or maintained upon the above described real property or within said easement and right-of-way any building or structure of any nature or kind that will interfere with the use of said easement and right-of-way by Grantee, its successors or assigns, or that will interfere with the ingress or egress along said easement by said Grantee, its successors or assigns.

The Grantee hereby covenants and agrees for itself, its successors and assigns, not to prevent the Grantors, their heirs, successors and assigns, from crossing over said real property and agrees that the Grantors, their heirs, successors and assigns may enjoy the continued use of the surface of said real property herein described, subject to the conditions above stated; and the Grantee hereby covenants and agrees that after the installation of any pipeline by it, in any excavation made by it, in the above described easement and right-of-way, it will backfill any such excavation made by it so as to fill said excavation as nearly as practicable to the level of the surrounding ground, and will replace any oiled, asphalt or concrete surface with like material and will replace any fence removed by it.

Executed this \_\_\_\_\_ day of \_\_\_\_\_, 2023.

**GRANTOR**

\_\_\_\_\_  
Signature line

\_\_\_\_\_  
Signature line

This is to certify that the interest in real property conveyed by the foregoing deed or grant to the **GRANADA COMMUNITY SERVICES DISTRICT**, a governmental agency, is hereby accepted on behalf of the Board of Directors of said District and the District consents to recordation thereof by its duly authorized officer.

Dated \_\_\_\_\_

\_\_\_\_\_  
Chuck Duffy, General Manager  
Granada Community Services District



**EXHIBIT A – LEGAL DESCRIPTION  
EASEMENT GRANTED TO GRANADA SANITARY DISTRICT  
6' Wide Easement Within 1230 Columbus Street, El Granada**

**Assessor Parcel No. 047-288-030**

Situate in unincorporated El Granada, County of San Mateo, State of California, and being a portion of Lot 24, Block 13, as shown on that certain subdivision map entitled, "Plat of Subdivision No. 1 of Granada," which was filed in the Office of the County Recorder of San Mateo County, State of California, on November 18, 1907, in Book 5 of Maps, at Page 43, being more particularly described as follows:

**COMMENCING** at the most westerly corner of Lot 21, Block 13 (5 Maps 43), being marked on the ground by a  $\frac{3}{4}$ " iron pipe with plastic plug and tack, "LS 3544";

1. Thence along the southwesterly line of Lots 21-23, South 26°16'42" East, a distance of 70.34 feet, to the most westerly corner of Lot 24, being the **POINT OF BEGINNING** of this description;
2. Thence along the northwesterly line of said Lot 24, North 61°31'03" East, a distance of 6.00 feet;
3. Thence leaving said line, South 26°16'42" East, a distance of 6.00 feet;
4. Thence South 61°31'03" West, a distance of 6.00 feet, to the southwesterly line of said Lot 24;
5. Thence along the southwesterly line of said Lot, North 26°16'42" West, a distance of 6.00 feet, to the **POINT OF BEGINNING**.

**END OF DESCRIPTION**

The herein described parcel is shown on the attached map, Exhibit "B", of this legal description, and is made a part hereof.

Containing an area of 36 square feet, more or less



Bryan G. Taylor, PLS  
License No. 7551, Expires 12/31/23



08/11/2023

Date



DATE: 08/10/2023

**COLUMBUS STREET**  
[50' WIDE]

PLAT OF SUBDIVISION  
NO. 1 OF GRANADA  
BOOK 5 MAPS 43  
BLOCK 13

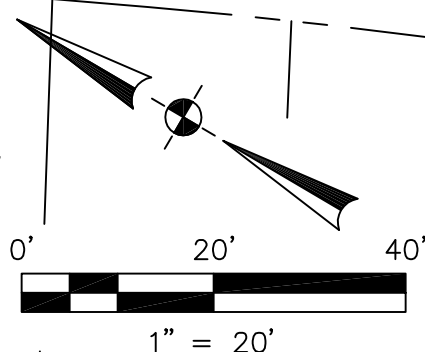

**SANTA MARIA AVENUE**  
[60' WIDE]

LOT 21      LOT 22      LOT 23      LOT 24      LOT 25

APN 047-288-250  
[422 SANTA MARIA AVE.]

APN 047-288-030  
[1230 COLUMBUS ST.]

EASEMENT GRANTED TO  
GRANADA SANITARY DISTRICT  
36 SQ. FT.±

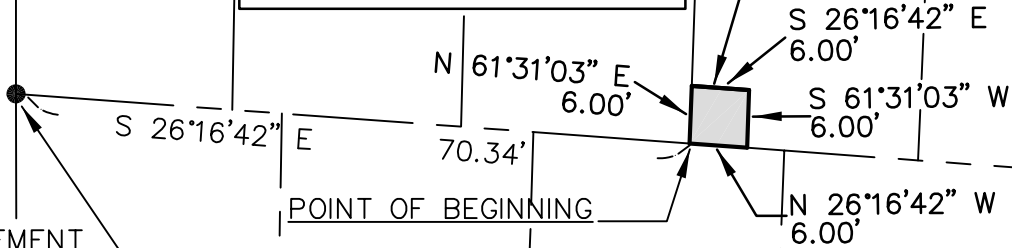

POINT OF COMMENCEMENT  
3/4" IRON PIPE "LS 3544"  
AT COMMON LOT CORNER  
FOR LOTS 20/21

LOT 20      LOT 19      LOT 18      LOT 17

**PLAT ACCOMPANYING LEGAL DESCRIPTION**

**EXHIBIT "B"**



EASEMENT WITHIN 1230 COLUMBUS STREET  
EL GRANADA (UNINCORPORATED)  
APN 047-288-030, SAN MATEO COUNTY, CA

SCALE PAGE  
1"=20' 2 OF 2  
JOB 23-072

**WHEN RECORDED, PLEASE MAIL  
THIS INSTRUMENT TO:**

District Administrator  
Granada Community Services District  
P.O. Box 335  
El Granada, CA 94018

**SPACE ABOVE FOR  
RECORDER'S USE ONLY**

**QUITCLAIM OF EASEMENT**

**NO TRANSFER TAX DUE**

Assessor's Parcel No.: 047-288-250

The undersigned Grantor declares that for valuable consideration, receipt of which is hereby acknowledged, the Granada Community Services District does hereby remise, release, and forever quitclaim, unto the owner or owner(s) of record of the real property hereinafter described, that certain Easement and Agreement dated \_\_\_\_\_ as shown on the attached Instrument Document No. \_\_\_\_\_ of the Official Record of the County of San Mateo.

The real property in which said easement is quitclaimed is in the unincorporated area of the County of San Mateo, State of California.

Executed this \_\_\_\_\_ day of \_\_\_\_\_, 2023.

**GRANTOR**

\_\_\_\_\_  
Granada Community Services District  
By: Chuck Duffy, its General Manager



RECORDER'S OFFICE  
SAN MATEO COUNTY

VCL 4596 PAGE 266

JEL:jw  
345 Cert. of Accept.

CERTIFICATE OF ACCEPTANCE

This is to certify that the interest in real property conveyed by the deed of easement dated November 13, 1963, from Charles J. Peterson and Helen L. Peterson, his wife,

as Grantor(s) to the GRANADA SANITARY DISTRICT, a public corporation, is hereby accepted by JOHN E. LYNCH, for and on behalf of said District, pursuant to Granada Sanitary District Resolution No. 89, a certified copy of which was recorded on July 5, 1963, at 2:23 p.m., No. 12650W, in the Office of the Recorder of the County of San Mateo, State of California, and the grantee consents to the recordation of said deed.

Dated: November 20, 1963

WILSON, HARZFELD, JONES & MORTON

By

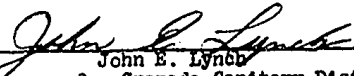
  
John E. Lynch  
Attorneys for Granada Sanitary District,  
A Public Corporation

635854

JEL:vb  
345  
Granada SD v. Nelson

DEED OF EASEMENT

CHARLES J. PETERSON and HELEN L. PETERSON, his wife,

as Grantor(s) hereby grant(s) to the GRANADA SANITARY DISTRICT, a public corporation, San Mateo County, California, an easement for a sanitary sewer main and appurtenances and work auxiliary thereto, in, over, across and upon the parcel(s) of land situate in the County of San Mateo, State of California, and more particularly described in Exhibit "A", attached hereto and by this reference made a part hereof; and in addition thereto, a temporary secondary easement five (5) feet on either side of said parcel(s) of land, limited in time to the period required to install said sanitary sewer main, for the purpose of moving therein and thereon machines and equipment, and of depositing thereon and removing therefrom excavated materials.

IN WITNESS WHEREOF, the Grantor(s) have hereunto set their hand(s) and signature(s) this 13th day of November, 1963.

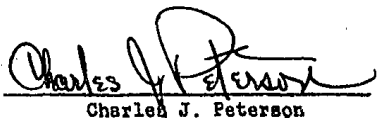
  
Charles J. Peterson

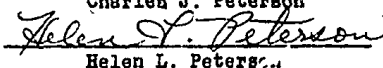
  
Helen L. Peters...

WITNESS:

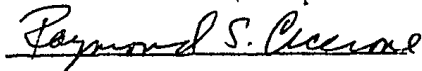
  
Raymond S. Ciccone

RECORDER'S OFFICE  
SAN MATEO COUNTY

VC 4596 PAGE 268

JEL:vb  
345  
Granada S.D. v. Nelson

EXHIBIT "A"

All that certain real property situate in the County of San Mateo, State of California, and more particularly described as follows:

Parcel 617

A portion of Lot(s) 21 and 22, Block 13, as said Lot(s) and Block(s) are shown on that certain map entitled, "PLAT OF SUBDIVISION NO 1 OF GRANADA, SAN MATEO COUNTY, CALIF.", which map was filed in the office of the Recorder of the County of San Mateo, California, on November 18, 1907 in Book 5 of maps at page 43, and described as follows:

A strip of land 6.00 feet in width, measured at right angles, lying contiguous to and northeasterly of the south-westerly line of said Lot(s) 21 and 22 and extending from the southerly line of Santa Maria Ave. to the south-easterly line of said Lot(s) 22.

RECORDER'S OFFICE  
SAN MATEO COUNTY

VCL 4596 PAGE 269

JEL:sb:vb Acknowledgment Form - Individuals 3/63 -200

STATE OF CALIFORNIA }  
COUNTY OF San Francisco } ss.

On this 13<sup>th</sup> day of November, 1963, before  
me, Louis W. Jacobovich, a Notary Public  
in and for the County of San Francisco, State  
of California, residing therein, duly commissioned and sworn,  
personally appeared Charles J. Peterson and Helen L. Peterson,  
his wife.

known to me to be the persons whose names are subscribed to  
the within instrument and acknowledged to me that they executed  
the same.

IN WITNESS WHEREOF, I have hereunto set my hand and  
affixed my official seal the day and year in this certificate first  
above written.

Louis W. Jacobovich  
Notary Public in and for said  
County of San Francisco  
Notary Public  
San Francisco County  
State of California (SEAL)  
My Commission Expires:  
MY COMMISSION EXPIRES MARCH 14, 1967

VCL 4596 PAGE 266

63585W

RECORDED AT REQUEST OF

Wilson, Hargfield, Jones + Hunter, attys.  
NOV 21 1 15 PM 1963

OFFICIAL RECORDS  
SAN MATEO COUNTY  
Paul Kincaid  
RECORDER

**WHEN RECORDED, PLEASE MAIL  
THIS INSTRUMENT TO:**

Secretary, Board of Directors  
Granada Community Services District  
P.O. Box 335  
El Granada, CA 94018

**SPACE ABOVE FOR  
RECORDER'S USE ONLY**

**EASEMENT**

**NO TRANSFER TAX DUE**

**Sewer Lines and Appurtenances**

Assessor's Parcel No.: 047-288-250

Project Name: Pollard Sewer Main Extension

**Fran Pollard**, hereinafter designated Grantor(s) and owner(s) of the hereinafter described lands, for valuable consideration, do(es) hereby GRANT and CONVEY to the **GRANADA COMMUNITY SERVICES DISTRICT**, herein designated Grantee, a perpetual easement and right-of-way upon, through, under, over and across the hereinafter described real property for the installation, construction, operation, maintenance, repair, replacement, and reconstruction of sewer pipe lines and/or mains, manholes, sewer lateral pipe lines, and all structures incidental thereto, together with the perpetual right to remove buildings, structures, trees, bushes, undergrowth, flowers, and any other obstructions interfering with the use of said easement and right-of-way by Grantee, its successors or assigns and in addition thereto, to remove soil and other materials within said easement and right-of-way and to use the same in such manner and at such locations as said Grantee may deem proper, needful or necessary in the construction, reconstruction and maintenance of said sewer lines or structures incidental thereto.

To have and to hold said easement and right-of-way unto itself and unto its successors and assigns forever.

The real property referred to herein and made subject to said easement and right-of-way by this grant is situated in the County of San Mateo, State of California, and is particularly described as follows:

SEE EXHIBIT "A" (LEGAL DESCRIPTION) AND EXHIBIT "B" (EASEMENT PLAT) ATTACHED HERETO AND MADE A PART HEREOF.

The Grantors may, at their own risk, use the surface of the above described real property in a manner that will not interfere with or be detrimental to the use of said easement and right-of-way by Grantee, its successors and assigns, provided no trees shall be planted or grown thereon.

The Grantors hereby covenant and agree for themselves, their heirs, successors and assigns, that there shall not be constructed or maintained upon the above described real property or within said easement and right-of-way any building or structure of any nature or kind that will interfere with the use of said easement and right-of-way by Grantee, its successors or assigns, or that will interfere with the ingress or egress along said easement by said Grantee, its successors or assigns.

The Grantee hereby covenants and agrees for itself, its successors and assigns, not to prevent the Grantors, their heirs, successors and assigns, from crossing over said real property and agrees that the Grantors, their heirs, successors and assigns may enjoy the continued use of the surface of said real property herein described, subject to the conditions above stated; and the Grantee hereby covenants and agrees that after the installation of any pipeline by it, in any excavation made by it, in the above described easement and right-of-way, it will backfill any such excavation made by it so as to fill said excavation as nearly as practicable to the level of the surrounding ground, and will replace any oiled, asphalt or concrete surface with like material and will replace any fence removed by it.

Executed this \_\_\_\_\_ day of \_\_\_\_\_, 2023.

**GRANTOR**

\_\_\_\_\_  
Signature line

This is to certify that the interest in real property conveyed by the foregoing deed or grant to the **GRANADA COMMUNITY SERVICES DISTRICT** a political corporation and/or governmental agency, is hereby accepted on behalf of the Board of Directors of said District and the District consents to recordation thereof by its duly authorized officer.

Dated \_\_\_\_\_

\_\_\_\_\_  
Chuck Duffy, General Manager  
Granada Community Services District

**EXHIBIT A – LEGAL DESCRIPTION  
EASEMENT GRANTED TO GRANADA SANITARY DISTRICT  
6' Wide Easement Within 422 Santa Maria Avenue, El Granada**

**Assessor Parcel No. 047-288-250**

Situate in unincorporated El Granada, County of San Mateo, State of California, and being a portion of Lots 21-23, Block 13, as shown on that certain subdivision map entitled, "Plat of Subdivision No. 1 of Granada," which was filed in the Office of the County Recorder of San Mateo County, State of California, on November 18, 1907, in Book 5 of Maps, at Page 43, being more particularly described as follows:

**BEGINNING** at the most westerly corner of said Lot 21, being marked on the ground by a ¾" iron pipe with plastic plug and tack, "LS 3544";

1. Thence along the northwesterly line of said Lot 21, North 59°26'18" East, a distance of 6.02 feet;
2. Thence leaving said line, South 26°16'42" East, a distance of 70.56 feet, to the southeasterly line of Lot 23;
3. Thence along said southeasterly line, South 61°31'03" West, a distance of 6.00 feet, to the southerly corner of said Lot 23;
4. Thence along the southwesterly line of Lots 23-21, North 26°16'42" West, a distance of 70.34, to the **POINT OF BEGINNING**.

**END OF DESCRIPTION**

The herein described parcel is shown on the attached map, Exhibit "B", of this legal description, and is made a part hereof.

Containing an area of 423 square feet, more or less



\_\_\_\_\_  
Bryan G. Taylor, PLS  
License No. 7551, Expires 12/31/23



08/11/2023

\_\_\_\_\_  
Date

**COLUMBUS STREET**  
[50' WIDE]

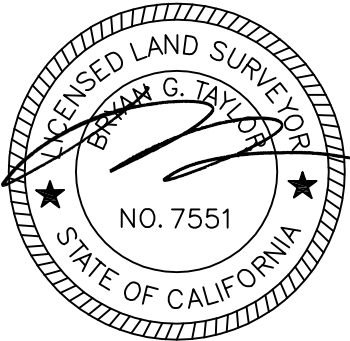
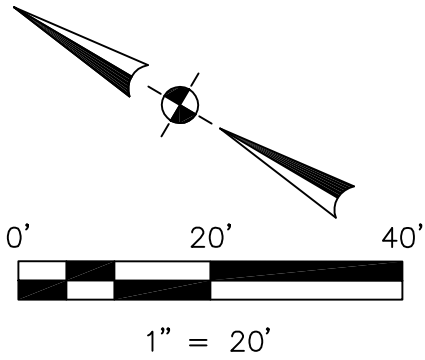

DATE: 08/10/2023

**SANTA MARIA AVENUE**  
[60' WIDE]

PLAT OF SUBDIVISION  
NO. 1 OF GRANADA  
BOOK 5 MAPS 43  
BLOCK 13

LOT 21

LOT 22

LOT 23

LOT 24

APN 047-288-250  
[422 SANTA MARIA AVE.]

EASEMENT GRANTED TO  
GRANADA SANITARY DISTRICT  
423 SQ. FT.±

N 59°26'18" E  
6.02'

S 26°16'42" E

70.56'

N 26°16'42" W

70.34'

S 61°31'03" W  
6.00'

POINT OF BEGINNING  
3/4" IRON PIPE "LS 3544"  
AT COMMON LOT CORNER  
FOR LOTS 20/21

LOT 20

LOT 19

LOT 18

**PLAT ACCOMPANYING LEGAL DESCRIPTION**

**EXHIBIT "B"**



EASEMENT WITHIN 422 SANTA MARIA AVENUE  
EL GRANADA (UNINCORPORATED)  
APN 047-288-250, SAN MATEO COUNTY, CA

SCALE PAGE  
1"=20' 2 OF 2  
JOB 23-072



**ITEM #3**

Blank

**GRANADA COMMUNITY SERVICES DISTRICT**

---

---

**AGENDA MEMORANDUM**

---

---

To: Board of Directors  
From: Hope Atmore, Assistant General Manager  
Subject: Resolution Authorizing District Staff to Participate in the State Disability Insurance Program  
Date: August 17, 2023

---

Attached for Board consideration is a Resolution which would enable District employees to participate in the California State Disability Insurance Program (SDI). It was discovered by a staff member after applying for SDI that the Granada Community Services District had not signed up for participation in the State program. Further, because the District does not provide a short term disability program directly, staff are concerned for their financial security should they become temporarily disabled.

Employee participation in SDI is optional and contributions are established by the California Employment Development Department (EDD). Participation in the program will be at the employee's expense through payroll deduction, with no cost to the District itself. It is my recommendation that your board approve the district's enrollment into the State Disability Insurance Program.

**GRANADA COMMUNITY SERVICES DISTRICT**

**RESOLUTION NO. 2023-\_\_**

**RESOLUTION AUTHORIZING DISTRICT STAFF TO PARTICIPATE IN THE CALIFORNIA STATE DISABILITY INSURANCE PROGRAM AT THEIR OWN EXPENSE**

**WHEREAS**, the Granada Community Services District has not previously been enrolled in the State Disability Insurance Program (SDI); and

**WHEREAS**, the District does not offer a regular short-term disability program, which has been a cause of concern for employees if they are temporarily disabled; and

**WHEREAS**, District employees have indicated an interest in participating in the SDI plan at their own expense, and employee participation in SDI is optional for each employee; and

**WHEREAS**, on or before October 31<sup>st</sup> of each year, the California Employment Development Department (EDD) sets the SDI rate for the following year; and

**WHEREAS**, payment for participation in the SDI plan is accomplished through a payroll deduction for each participating employee; and

**WHEREAS**, this proposed resolution authorizes eligible employees to participate in the SDI plan if they so desire;

**NOW, THEREFORE, BE IT RESOLVED** by the Board of Directors of the Granada Community Services District:

**Section 1. Approval of Application for State Disability Insurance.** The District approves an authorized officer to make the application for enrollment in the State Disability Insurance program to the Employment Development Department (EDD) for district employees.

**Section 2. Official Actions.** The Authorized Officer and all other designated Officers of the District are hereby authorized and directed to, for and in the name and on behalf of the District, to do any and all things and take any and all actions, including making the application with EDD and notifying all employees. Whenever in this resolution any other execution, countersigning or action may be taken on behalf of such officer by any person designated by such officer to act on his or her behalf in the case such officer is absent or unavailable.

**Section 3. Effective Date.** This resolution shall take effect from and after the date of approval and adoption thereof.

The above and foregoing Resolution was regularly introduced and thereafter adopted and approved at the Regular Meeting of the Board of Directors of the Granada Community Services District held on August 17, 2023, by the following vote:

- AYES:
- NOES:
- ABSTAIN:
- ABSENT:

Attest:

\_\_\_\_\_  
Nancy Marsh, Board President



# ITEM #4

Blank



**GRANADA COMMUNITY SERVICES DISTRICT**

---

**AGENDA MEMORANDUM**

---

To: Board of Directors  
From: Chuck Duffy, General Manager  
Subject: Consideration of Directors Compensation  
Date: August 17, 2023

---

This item was requested by the Board at our last board meeting. The current meeting stipend for directors is \$145 per meeting.



# ITEM #5

Blank

**GRANADA COMMUNITY SERVICES DISTRICT**

---

**AGENDA MEMORANDUM**

---

To: Board of Directors  
From: Chuck Duffy, General Manager  
Subject: Consideration of Revised Starting Time for Regular District Board Meetings  
Date: August 17, 2023

---

This item was requested by the Board at our last board meeting. The current district policy stipulates a starting time of 7:30 pm for Regular Board Meetings.



**ITEM #6**

Blank



**GRANADA COMMUNITY SERVICES DISTRICT**

---

---

**AGENDA MEMORANDUM**

---

---

To: Board of Directors

From: Hope Atmore, Assistant General Manager

Subject: Board Consideration of Letter of Support of the Midcoast Community Council

Date: August 17, 2023

---

Per Director request, this item is for board consideration. Following similar letters of support by other District Boards and agencies, GCSD wishes to show support for a proposal by the Midcoast Community Council to urge San Mateo County to fund planning for a broadband initiative that would serve the Coastside.



## GRANADA COMMUNITY SERVICES DISTRICT

*Board of Directors*

*Nancy Marsh, President  
Jen Randle, Vice President  
Matthew Clark, Director  
Barbara Dye, Director  
Jill Grant, Director*

August 17, 2023

To: Midcoast Community Council  
P.O. Box 248  
Moss Beach, CA 94037

On behalf of the Granada Community Services Board of Directors, I am writing to express my concerns regarding the poor internet connection on the San Mateo Coastsides. As you may know, this issue poses a significant threat to safety and well-being, and residents demand immediate action to address it.

If corporations are unwilling to invest in building better networks for our communities, and regulators will not hold them accountable, then it's up to the communities themselves to take matters into their own hands. By building their own fiber networks, small communities will ensure that they have access to reliable and high-quality internet services that meet their unique needs.

Community leaders can work together to secure grants and funding from various government and private sources to make these projects a reality. We ask our legislators to prioritize the interests of the people they represent and pass laws that encourage and support community-led initiatives to bridge the digital divide.

Our community is taking proactive steps to empower ourselves and ensure that everyone has access to the essential services they need, including reliable internet access. I urge you to prioritize this issue and take action to support community-led initiatives to improve internet connectivity on the San Mateo Coastsides. Thank you for your attention to this critical issue.

Sincerely,

GRANADA COMMUNITY SERVICES DISTRICT

---

Nancy Marsh, GCSD Board President

**ITEM #7**

Blank

August 10, 2023

## **Memorandum**

To: Granada Community Services District

From: Xiangquan Li, Kennedy Jenks Consultants, filling in for John H. Rayner, District Engineer

Subject: Engineer's Report for August 2023

---

### **6-Year CIP. Project 2**

The project construction is complete. District filed Notice of Completion to San Mateo County who recorded on July 26. District received recorded Notice of Completion and receipt from County Recorder's office. A copy of the Notice of Completion is included in the agenda packet. District is reviewing the As-Built drawing markups with the Contractor. If there are no outstanding questions, District will release the five percent (5%) retention to the Contractor.

### **Big Wave**

Construction of the Airport Street mainline sewer is complete and meets GCSD specifications. However, the County has rejected the Contractor's trench pavement and the County will not sign off on its encroachment permit until the trench pavement is approved. Contractor is still performing pavement restoration to meet County requirements. Also, for record purposes, we need to receive plans from the Contractor showing any changes in design made during construction. We will not recommend dedication of the mainline extension to the GCSD collection system until these issues are resolved.

### **Harbor Village RV Park**

The construction for the RV Park at 100 Capistrano Road is underway. The project includes a new manhole on District sewer at the intersection of Capistrano Road and Pillar Point Harbor Boulevard. District witnessed the manhole test and it passed. District will inspect again when the manhole rim, cover and asphalt are finished. If acceptable, District will issue a formal notice of acceptance.

### **Pillar Point Harbor RV Park Public Restroom Project**

Construction is underway and is anticipated to complete this month.

## **Memorandum**

Granada Community Services District  
August 10, 2023

### **Pillar Point Harbor Sewage Meter**

On July 26, District Engineer and Assistant General Manager reviewed the meter installation with Harbor District staff. Information was gathered which is being reviewed by KJ to determine if the installation is approved for billing sewage flows.

### **SAM Meeting with Member Agency Engineers re Failure of SAM's Montara FM**

SRT Consultants has begun working on the design of the replacement of SAM's Montara Force Main. District expect to receive a copy of SRT Consultant's design submittal soon. Separately, Exponent has been retained by SAM to evaluate ductile iron pipe failure on SAM's Montara Force Main. District has received a copy of the draft report. Agency engineers had a Zoom meeting with Exponent on July 31 to review Exponent's draft report on the force main failure. The report will be revised in accordance with comments provided during the meeting before being placed on the SAM Board agenda.

### **Update of GCSD Standard Specifications and Details**

We have completed our initial review of the 2003 GCSD standard specifications and construction details and are now incorporating the proposed changes into draft documents for review. We now expect to have the draft documents available for review in mid-September.

REQUESTED BY

Granada Community Services District

AND WHEN RECORDED MAIL TO:

Granada Community Services District  
P.O. Box 335  
El Granada, CA 94018

For Recorder's



GC 27383

NOTICE OF COMPLETION  
(Public Work of Improvement)

Notice is hereby given that:

1. The undersigned is owner of the interest or estate stated below in the property hereinafter described.
2. The full name of the undersigned is Granada Community Services District
3. The full address of the undersigned is: 504 Avenue Alhambra, 3rd floor, El Granada, CA 94018.
4. The nature of the title of the undersigned is: District Engineer
5. A work of improvement on the property hereinafter described was completed on June 27, 2023.
6. The name of the contractor, if any, for such work of improvement was: Koios Engineering, Inc.  
The property on which said work of improvement was completed in the unincorporated community of El Granada in the County of San Mateo, State of California, and is described as follows:

Project Name: 2022 CIP, Sewer Replacement Project 2

Work Done: Replacing sanitary sewer lines, manholes and related facilities, and repairs to existing manholes within the community of El Granada in San Mateo County, CA.

8. The street address of said property is: None  
(If no street address has been officially assigned, insert "none")

Dated: July 5, 2023

GRANADA COMMUNITY SERVICES DISTRICT

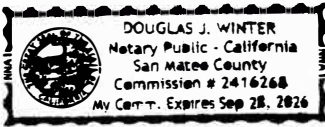

By: *[Signature]*

State of California

Verification

County of San Mateo

The undersigned being duly sworn, says: On this 21 day

of July, 2023 before me, personally appeared

HOPE ATMON, personally known to me (or proved to me on the basis of satisfactory evidence) to be the person(s) whose name(s) is/are subscribed to the within instrument and acknowledged to me that he/she/they executed the same in his/her/their authorized capacity(ies), and that by his/her/their signature(s) on the instrument the person(s), or the entity upon behalf of which the person(s) acted, executed the instrument.

I am the Assistant General Manager of the Granada Community Services District, owner of the public work above described, and am authorized to make this verification on its behalf. The statements in the foregoing document are true of my own knowledge, except as to those matters which are stated therein on information and belief, and as to those matters I believe them to be true.

I declare under penalty of perjury that the foregoing is true and correct.

Executed on July 21 2023at

HALF MOON BAY, California.

SUBSCRIBED AND SWORN TO before me

Signature

*[Signature]*

Notary Public in and for said State

Commission No.

2416268

*[Signature]*  
Board President / ASST. GEN. MGR.  
Granada Community Services District

County of San Mateo  
Clerk-Recorder  
Mark Church  
555 County Center  
Redwood City, CA 94063  
(650) 363-4500

---

Receipt No.: RPT20230038481

Finalization No.: 2023037796

Cashier: 32

Register: 015

Date/Time: 07/26/2023 01:57 PM

Item	Title	Count
1	NC	1
Notice of Completion		
Document No.:	2023-035921	
Recording Time:	01:57 PM	
Recording Total:	No Fee	
Conform Copy Total:	No Fee	
<hr/>		
Total Amount Due:	\$0.00	

Total Paid

No Fee

Amount Due: \$0.00

THANK YOU  
PLEASE RETAIN THIS RECEIPT  
FOR YOUR RECORDS

<https://www.smcacre.org/>



07/26/2023 01:59 PM



**ITEM #8**

Blank



## **SEWER AUTHORITY MID-COASTSIDE**

### **Board of Directors Meeting Agenda**

#### ***Regular Board Meeting 7:00 PM, Monday, August 14, 2023***

SAM Administration Building, 1000 N. Cabrillo Highway, Half Moon Bay, CA 94019

This meeting will be held in-person and via zoom for public participation. Access to this meeting will be available to the public via in person attendance, or by either computer web-link or telephone audio as noted below.

Join Zoom Meeting

<https://us02web.zoom.us/j/86104189427?pwd=MFo2SIZUaW51Z3NMU3k1cXhOL2Y0Zz09>

Meeting ID: 861 0418 9427

Passcode: 782088

Dial by your location

• +1 669 900 6833 US (San Jose)

Please note that this meeting will be held in person at the SAM Administration Building. As a convenience for the public, the meeting may also be accessed by Zoom Webinar and will be available by either computer or telephone audio as indicated below. Because this is an in-person meeting, and the Zoom component is not otherwise legally required, but rather is being offered as a convenience to the public, if there are technical issues during the meeting, this meeting will continue and will not be suspended.

If you have a disability and require special assistance related to participating in this meeting, please contact the Authority at least two working days in advance of the meeting at (650) 726-0124 or via email at [kishen@samcleanswater.org](mailto:kishen@samcleanswater.org).

#### **1. CALL TO ORDER**

A. Roll Call:	Chair:	Kathryn Slater-Carter (MWSD)
	Vice-Chair:	Barbara Dye (GCSD)
	Secretary/Treasurer:	Deborah Ruddock (HMB)
	Director:	Dr. Deborah Penrose (HMB)
	Director:	Peter Dekker (MWSD)
	Director:	Matthew Clark (GCSD)

**2. PUBLIC COMMENT / ORAL COMMUNICATION/ ITEMS NOT ON THE AGENDA**

Members of the public are welcome to provide publiccomment in person, or via computer web-link/telephone on items not on the agenda at this time. Members of the public may also comment via e-mail by sending email comments to [kishen@samcleanswater.org](mailto:kishen@samcleanswater.org). All comments so submitted prior to 7 pm on June 12, 2023 will be read out loud during the discussion of the respective item(s) identified in the e-mail; written comments without such identification shall be read during this Item. Members of the public may also provide comments in person, telephonically, or electronically on individual items on the agenda following recognition by the Board Chair presiding over the meeting.

**3. CONSENT AGENDA** *(Consent items are considered routine and will be approved/ adopted by a single motion and vote unless a request for removal for discussion or explanation is received from the public or Board.)*

A. Approve Minutes of July 24, 2023 Regular Board Meeting (**Attachment**)

B. Approve Disbursements for August 14, 2023 (**Attachment**)

**4. REGULAR BUSINESS** *(The Board will discuss, seek public input, and possibly take action on the following items)*

A. Status Update on Annual Comprehensive Financial Report submitted to Government Finance Officers Association (GFOA) for Fiscal Year Ended June 30, 2022 (**Attachment**)

B. Authorize General Manager to Enter Into a Services Agreement with Wastewater Solids Management Co. for Primary Digester Cleaning at the Treatment Plant in an Amount not to exceed \$159,960.00 (**Attachment**)

C. Authorize General Manager to Enter a Contract with JMB Construction for the Princeton Pump Station Rehabilitation Project in the Amount of \$1,637,650 (**Attachment**)

**5. GENERAL MANAGER’S REPORT**

**6. ATTORNEY’S REPORT**

**7. DIRECTORS’ REPORT**

**8. TOPICS FOR FUTURE BOARD CONSIDERATION** (**Attachment**)

**9. CONVENE IN CLOSED SESSION** *(Items discussed in Closed Session comply with the Ralph M. Brown Act.)*

A. CONFERENCE WITH LEGAL COUNSEL — ANTICIPATED LITIGATION

Pursuant to Paragraph (4) of Subdivision (d) of Government Code Section 54956.9 (Two potential cases)

**B. CONFERENCE WITH LEGAL COUNSEL — PENDING LITIGATION**

Pursuant to Paragraph (1) of Subdivision (d) of Government Code Section 54956.9, *Ecological Rights Foundation v. Sewer Authority Mid-Coastside* (Case No: 3:18-CV-04413)

**C. CONFERENCE WITH LEGAL COUNSEL – EXISTING LITIGATION**

Pursuant to Government Code Paragraph (1) of Subdivision (d) of Section 54956.9: (*Half Moon Bay v. Granada CSD, Montara WSD & Sewer Authority Mid-Coastside*)

**10. CONVENE IN OPEN SESSION** (*Report Out on Closed Session Items*)

**11. ADJOURNMENT**

- Upcoming Regular Board Meetings: August 28, 2023 and September 11, 2023

*The meeting will end by 9:00 p.m. unless extended by Board vote*

-----

**INFORMATION FOR THE PUBLIC**

This agenda contains a brief description of each item to be considered. Those wishing to address the Board on any matter not listed on the Agenda, but within the jurisdiction of the Board, may do so during the Public Comment section of the Agenda and will have a maximum of three minutes to discuss their item. The Board Chair will recognize those wishing to speak on a matter listed on the Agenda at the appropriate time.

Any writing that is a public record and relates to an agenda item for an open session of a regular meeting that is distributed to the Board less than 72 hours prior to the meeting, is available for public inspection, during normal business hours, at the Authority’s office.

Board meetings are accessible to people with disabilities. Upon request, the Authority will make this agenda available in appropriate alternative formats to persons with a disability. In compliance with the Americans with Disabilities Act, the Authority will provide special assistance for participation in this meeting. Please submit requests for a disability-related modification or an accommodation in order to participate in the public meeting at least two working days in advance of the meeting by contacting the Authority at (650) 726-0124.



**SEWER AUTHORITY MID-COASTSIDE**  
**Staff Report**

---

**TO:** Honorable Board of Directors  
**FROM:** Kishen Prathivadi, General Manager  
**BY:** Kishen Prathivadi, General Manager  
**SUBJECT:** **Authorize General Manager to Enter a Contract with JMB Construction for the Princeton Pump Station Rehabilitation Project in the Amount of \$1,637,650**

---

**Executive Summary**

The purpose of this report is to authorize General Manager to award and enter into a contract with JMB Construction for the Princeton Pump Station Rehabilitation Project.

**Fiscal Impact**

The fiscal impact is not to exceed \$1,637,650. The budgeted amount in the adopted CIP 2022-2023 was \$1,263,181. A mid-year budget adjustment will need to be made at a later date to authorize the full anticipated cost of this critical project that is required by court order to be completed by June 30, 2024.

**Strategic Plan Compliance**

The recommendation complies with Goal 5 of the SAM Strategic Plan, “**Infrastructure, Operations, and Maintenance,**” Goal 5.3 – “**Develop a longest term reasonable perspective in concrete spending terms of potential alternative approaches to managing the system with the objective of decreasing long term costs and environmental impacts and increasing safety.**”

**Background and Discussion/Report**

The Princeton Pump Station (PPS) project is part of the Capital Improvement Program for Fiscal Year 2022 (CIP 4.01) and replaces the existing PPS with a buried package pump station. This project is a required component of the 2019 Consent Decree in the case of *Ecological Rights Foundation v. Sewer Authority Mid-Coastside* (Case No. 3:18-CV-04413) (“Consent Decree”), which settled a Clean Water Act Citizen suit against SAM. The Consent Decree was approved by the Federal District Court for the

---

BOARD MEMBERS:	M. Clark	B. Dye	P. Dekker
	D. Penrose	D. Ruddock	K. Slater-Carter
ALTERNATE MEMBERS:	S. Boyd	B. Softky	J. Randle
	J. Grant	H. Rarback	

Northern District of California and the court retained continuing jurisdiction to enforce the terms of the Consent Decree. In March 2021, and per the Consent Decree, a condition assessment study was conducted by SAM at the PPS. The PPS condition assessment identified three significant vulnerabilities at the existing pump station facility: tsunami, seismic fault rupture, and soil liquefaction potential. A feasibility study, which evaluated PPS alternatives and provided recommendations, was completed by SAM in June 2021. As noted, per the Consent Decree, SAM is required to implement the recommendations of the PPS feasibility study by June 30, 2024.

The PPS is located on West Point Avenue within the Granada Community Services District service area. PPS was originally constructed in the 1950s to convey sewage collected from the community in Princeton-by-the-Sea to a small local wastewater treatment plant. In 1979, the PPS flows were redirected to the new Intertie Pipeline System that conveys all wastewater from the northern communities of Montara, Moss Beach, Princeton-by-the-Sea, and El Granada to the SAM Regional WWTP in Half Moon Bay. PPS has not been upgraded in over 40 years and has exceeded its useful life. The reliability of the pumps is diminishing as they continue to age, and replacement parts are more difficult to obtain. In addition, the existing pump station requires high-risk, confined space entry whenever the pumps or valves need maintenance.

Based on the alternative analysis, seismic risk, condition assessment, and hydraulic analysis, the feasibility study recommended promptly building a new PPS on the current site and abandoning the existing pump station. The new package pump station will include a prefabricated wet well with submersible duplex grinder pumps mounted on rails for ease of routine removal, maintenance, and inspection. The existing MCC and generator system at the PPS will be used to serve the new pump station, which will be located in the open parking area outside of the MCC room. This project will provide efficiency in operation, flexibility during construction, and reliability for SAM.

Bid-ready documents, including detailed plans and technical specifications, were completed by the multi-discipline team of civil, structural, electrical, instrumentation and controls, and geotechnical engineering. Qualified contractors were invited to participate in mandatory pre-bid conferences, which included a visit to the pump station to ensure adequate time and attention was provided to all interested bidders. All bidder questions were answered via addenda before the bid submission date of Tuesday, August 8.

Four proposals were received and are as follows:

1. GSW Construction -\$1,496,350

---

BOARD MEMBERS:	M. Clark	B. Dye	P. Dekker
	D. Penrose	D. Ruddock	K. Slater-Carter
ALTERNATE MEMBERS:	S. Boyd	B. Softky	J. Randle
	J. Grant	H. Rarback	

2. JMB Construction-\$1,637,650
3. Minerva Construction-\$1,647,000
4. GSE Construction-\$1,870,100

References were checked for the bidders based on the “Statement of Experience” document provided by the bidders.

As explained below, the bid of GSW Construction – the apparent lowest bidder, was determined by SAM staff to not meet the Statement of Experience requirements in Article 3 of the bid specifications, .

Reproduced below, with pertinent requirements underlined, are the bid requirements in the SAM contract documents that SAM staff determined GSW Construction’s bid did not satisfy:

***Prime Contractor Pre-Qualification:***

***All potential bidders shall have been in business a minimum of five (5) years conducting similar pump station rehabilitation work during which time each potential bidder must have performed a minimum of three (3) directly related projects of similar scope, size, and complexity. All potential bidders must list these projects below in the space provided, to be included with each bid (listings on separate sheets is acceptable).***

***List at least three (3) jobs performed as Prime Contractor in the last 5 years that are representative of your company’s qualifications to perform the work required by the contract Documents. Start with the most recent jobs. Be specific when listing “Type of Work Performed”. Provide applicable references. Failure to provide this information will render the bid non-responsive and may disqualify the potential bidder from Contract award.***

GSW Construction was founded in March 2021 and has been in business since January 2022. They therefore do not qualify for the 5-year requirement, and their bid is non-responsive to this requirement identified by SAM.

Also on the two jobs listed in their bid, they were not the prime contractor.

Therefore, GSW Construction’s bid is non-responsive as it does not meet all required elements of the SAM contract documents and bid specifications. SAM is authorized by law to require strict compliance with its bid specifications, and GSW’s bid did not strictly comply with all of SAM’s bid specifications for this Project.

---

BOARD MEMBERS:	M. Clark	B. Dye	P. Dekker
	D. Penrose	D. Ruddock	K. Slater-Carter
ALTERNATE MEMBERS:	S. Boyd	B. Softky	J. Randle
	J. Grant	H. Rarback	



We checked the references for the second lowest bidder, JMB Construction, and their bid seems to be in order to meet all bid specifications for the project.

SAM's estimated total cost of the project is approximately \$2,300,000 as follows:

Construction- \$1,637,650  
Lighting, Electrical and Instrumentation & Control - \$ 450,000  
Project Management & Engineering- \$200,000

SAM intends to propose a mid-year budget adjustment as the 2022-23 budgeted amount for this project approved by the Board was \$1.26M.

**Staff Recommendation**

Staff recommends the Board to authorize the General Manager to: (1) reject the bid of GSW as non-responsive; (2) award the contract to the responsible bidder with the lowest responsive bid for the Project, JMB Construction, for the rehabilitation of the Princeton Pump Station in the Amount of \$1,637,650.

**Supporting Documents**

Attachment A: Proposal from GSW Construction  
Attachment B: Proposal from JMB Construction  
Attachment C: Proposal from Minerva Construction  
Attachment D: Proposal from GSE Construction

---

BOARD MEMBERS:	M. Clark	B. Dye	P. Dekker
	D. Penrose	D. Ruddock	K. Slater-Carter
ALTERNATE MEMBERS:	S. Boyd	B. Softky	J. Randle
	J. Grant	H. Rarback	



## SEWER AUTHORITY MID-COASTSIDE

### Board of Directors Meeting Agenda

#### ***Regular Board Meeting 7:00 PM, Monday, August 14, 2023***

SAM Administration Building, 1000 N. Cabrillo Highway, Half Moon Bay, CA 94019

This meeting will be held in-person and via zoom for public participation. Access to this meeting will be available to the public via in person attendance, or by either computer web-link or telephone audio as noted below.

Join Zoom Meeting

<https://us02web.zoom.us/j/86104189427?pwd=MFo2SIZUaW51Z3NMU3k1cXhOL2Y0Zz09>

Meeting ID: 861 0418 9427

Passcode: 782088

Dial by your location

• +1 669 900 6833 US (San Jose)

Please note that this meeting will be held in person at the SAM Administration Building. As a convenience for the public, the meeting may also be accessed by Zoom Webinar and will be available by either computer or telephone audio as indicated below. Because this is an in-person meeting, and the Zoom component is not otherwise legally required, but rather is being offered as a convenience to the public, if there are technical issues during the meeting, this meeting will continue and will not be suspended.

If you have a disability and require special assistance related to participating in this meeting, please contact the Authority at least two working days in advance of the meeting at (650) 726-0124 or via email at [kishen@samcleanswater.org](mailto:kishen@samcleanswater.org).

#### **1. CALL TO ORDER**

A. Roll Call:	Chair:	Kathryn Slater-Carter (MWSD)
	Vice-Chair:	Barbara Dye (GCSD)
	Secretary/Treasurer:	Deborah Ruddock (HMB)
	Director:	Dr. Deborah Penrose (HMB)
	Director:	Peter Dekker (MWSD)
	Director:	Matthew Clark (GCSD)

**2. PUBLIC COMMENT / ORAL COMMUNICATION/ ITEMS NOT ON THE AGENDA**

Members of the public are welcome to provide publiccomment in person, or via computer web-link/telephone on items not on the agenda at this time. Members of the public may also comment via e-mail by sending email comments to [kishen@samcleanswater.org](mailto:kishen@samcleanswater.org). All comments so submitted prior to 7 pm on June 12, 2023 will be read out loud during the discussion of the respective item(s) identified in the e-mail; written comments without such identification shall be read during this Item. Members of the public may also provide comments in person, telephonically, or electronically on individual items on the agenda following recognition by the Board Chair presiding over the meeting.

**3. CONSENT AGENDA** *(Consent items are considered routine and will be approved/ adopted by a single motion and vote unless a request for removal for discussion or explanation is received from the public or Board.)*

- A. Approve Minutes of July 24, 2023 Regular Board Meeting (**Attachment**)
- B. Approve Disbursements for August 14, 2023 (**Attachment**)

**4. REGULAR BUSINESS** *(The Board will discuss, seek public input, and possibly take action on the following items)*

- A. Status Update on Annual Comprehensive Financial Report submitted to Government Finance Officers Association (GFOA) for Fiscal Year Ended June 30, 2022 (**Attachment**)
- B. Authorize General Manager to Enter Into a Services Agreement with Wastewater Solids Management Co. for Primary Digester Cleaning at the Treatment Plant in an Amount not to exceed \$159,960.00 (**Attachment**)
- C. Authorize General Manager to Enter a Contract with JMB Construction for the Princeton Pump Station Rehabilitation Project in the Amount of \$1,637,650 (**Attachment**)

**5. GENERAL MANAGER’S REPORT**

**6. ATTORNEY’S REPORT**

**7. DIRECTORS’ REPORT**

**8. TOPICS FOR FUTURE BOARD CONSIDERATION** (**Attachment**)

**9. CONVENE IN CLOSED SESSION** *(Items discussed in Closed Session comply with the Ralph M. Brown Act.)*

- A. CONFERENCE WITH LEGAL COUNSEL — ANTICIPATED LITIGATION  
Pursuant to Paragraph (4) of Subdivision (d) of Government Code Section 54956.9  
(Two potential cases)

**B. CONFERENCE WITH LEGAL COUNSEL — PENDING LITIGATION**

Pursuant to Paragraph (1) of Subdivision (d) of Government Code Section 54956.9, *Ecological Rights Foundation v. Sewer Authority Mid-Coastside* (Case No: 3:18-CV-04413)

**C. CONFERENCE WITH LEGAL COUNSEL – EXISTING LITIGATION**

Pursuant to Government Code Paragraph (1) of Subdivision (d) of Section 54956.9: (Half Moon Bay v. Granada CSD, Montara WSD & Sewer Authority Mid-Coastside)

**10. CONVENE IN OPEN SESSION** (*Report Out on Closed Session Items*)

**11. ADJOURNMENT**

- Upcoming Regular Board Meetings: August 28, 2023 and September 11, 2023

*The meeting will end by 9:00 p.m. unless extended by Board vote*

-----

**INFORMATION FOR THE PUBLIC**

This agenda contains a brief description of each item to be considered. Those wishing to address the Board on any matter not listed on the Agenda, but within the jurisdiction of the Board, may do so during the Public Comment section of the Agenda and will have a maximum of three minutes to discuss their item. The Board Chair will recognize those wishing to speak on a matter listed on the Agenda at the appropriate time.

Any writing that is a public record and relates to an agenda item for an open session of a regular meeting that is distributed to the Board less than 72 hours prior to the meeting, is available for public inspection, during normal business hours, at the Authority’s office.

Board meetings are accessible to people with disabilities. Upon request, the Authority will make this agenda available in appropriate alternative formats to persons with a disability. In compliance with the Americans with Disabilities Act, the Authority will provide special assistance for participation in this meeting. Please submit requests for a disability-related modification or an accommodation in order to participate in the public meeting at least two working days in advance of the meeting by contacting the Authority at (650) 726-0124.

**MINUTES**  
**SAM BOARD OF DIRECTORS MEETING**  
*Regular Board Meeting 7:00 PM, Monday July 24, 2023*

**1. CALL TO ORDER**

Chair Slater-Carter called the meeting to order at 7:00 p.m. at the SAM Administration Building, located at 1000 N. Cabrillo Highway, Half Moon Bay, CA 94019.

A. Roll Call

Directors Clark, Penrose, Dekker, Dye, Ruddock, and Slater-Carter were present. Also present were General Manager Prathivadi, Finance Officer George Evens, Plant Superintendent Tim Costello, and General Counsel Jeremy Jungreis.

**2. PUBLIC COMMENT/ORAL COMMUNICATION/ITEMS NOT ON THE AGENDA**

Tyler Hawes from Civic Bell, a locally owned civic tech company, addressed the Board, and discussed the social platform that connects residents and local communities to their government officials at a local level to create a stronger communication between the two. He invited members of the community, residents, and other government officials to sign up, and use the free website/app. Gregg Dieguez, resident of Montara, followed up on getting an explanation of the winter storm flows that happen every December. Carlyse Ann Young, resident of Montara, spoke of the extensive tour of the SAM Plant that she had the previous week, and thanked Plant Superintendent Tim Costello. She also commented on the constant movement of the Owl camera. Peter Dekker, SAM Board Director, and MWSD Director stated how important it is to get the reports on the winter storm flows and the Water Hammer study. Chair Slater-Carter stated that they should be put on the agenda immediately after receiving and reviewing them. Director Clark stated that the reports should be distributed to the Board as soon as they are reviewed by SAM staff, and not wait for it to be on the agenda. General Manager Prathivadi gave an update on both reports, and stated that Integral Consulting is almost to the end of their study, and have completed the flood modeling. He also stated that he believes the study will be given to the engineers in August for approval, and then to SAM Board. General Manager Prathivadi stated Exponent Consulting has finished the water hammer study, and it is currently in the hands of the engineers, and once it has been reviewed by the engineers there will be an internal meeting. If there are changes they will be taken care of, and then passed on to the Board, and all concerned parties.

**3. CONSENT AGENDA** *(Consent items are considered routine and will be approved or adopted by one vote unless a request for removal for discussion or explanation is received from the Public or Board)*

A. Approve Minutes of June 26, 2023 Regular Board Meeting

B. Approve Disbursements for July 24, 2023

C. Monthly Revenue and Expense Report for Period Ending June 30, 2023

Director Clark commented that on page 6 of the minutes, an “s” should be added to the word “boiler” as it is more than one boiler, and should be plural. Director Penrose moved, and Director Ruddock seconded the motion to approve Agenda Items 3A – Approve Minutes of June 26, 2023 per Director Clarks’ comment, 3B – Approve Disbursements for July 24, 2023, and agenda 3C - Monthly Revenue and Expense Report for Period Ending June 30, 2023.

Penrose/Ruddock/8 Ayes/0 Noes. The motion passed.

**4. REGULAR BUSINESS** *(The Board will discuss, seek public input, and possibly take action on the following items)*

- A. Adopt Resolution 7-2023 Adopting the Sewer Authority Mid-Coastside General Budget for Fiscal Year 2023/24 and Adopting the Position Control List

General Manager Prathivadi reviewed the staff report, and recommended that the Board of Directors adopt Resolution 7-2023 adopting the General Budget for FY 2023/24 and the Position Control list as presented. Director Dekker moved, and Director Penrose seconded the motion to adopt Resolution 7-2023, a resolution adopting the SAM General Budget for FY 2023/24 and the Position Control List.

Dekker/Penrose/8 Ayes/0 Noes. The motion passed.

- B. Set Salary and Terms and Conditions of Employment for Unrepresented Employees and Approve Unrepresented Employees’ Salary Schedule, Retroactive to July 1, 2023

General Manager Prathivadi discussed the salary, and terms & conditions of employment for unrepresented employees, and approval of the unrepresented employees salary schedule, retroactive to July 1, 2023, and recommended that the Board consider and approve a 3% cost-of-living adjustment, effective July 1, 2023 for the Authority’s unrepresented employees. Director Ruddock moved, and Director Dekker seconded the motion to approve a 3% cost-of-living adjustment, effective July 1, 2023 for the Authority’s unrepresented employees.

Ruddock/Dekker/8 Ayes/0 Noes. The motion passed.

- C. Set Bi-Weekly Employee Salary Schedule, Effective July 1, 2023

General Manager Prathivadi reviewed the staff report, and recommended the Board of Directors set and approve the bi-weekly employee salary schedule, effective July 2023.

Director Ruddock moved, and Director Dekker seconded the motion to set and approve the bi-weekly employee salary schedule effective July 1, 2023.

Ruddock/Dekker/8 Ayes/0 Noes. The motion passed.

## **5. GENERAL MANAGER'S REPORT**

### **A. Monthly Manager's Report – June 2023**

General Manager Prathivadi stated that staff is there to answer any questions regarding the June 2023 Monthly Managers Report. Chair Slater-Carter moved on to the next agenda item.

## **6. ATTORNEY'S REPORT**

General Counsel Jungreis had nothing to report. Chair Slater-Carter asked General Counsel about the timeline on mediation regarding PFAS (Per-fluorinated Alkylated Substances), and PFOS (Per-fluorooctane Sulfonic Acid), and why they are coming after sewer plants, and manufacturers. A discussion ensued. General Counsel Jungreis stated he would bring more information at the next Board meeting. Following discussion, Chair Slater-Carter moved on to the next agenda item.

## **7. DIRECTOR'S REPORT**

Director Dye commented on the set-up of the Owl camera. A discussion ensued. It was suggested that directions on how to set the view on an attendee's computer could be added to the top of the agenda.

## **8. TOPICS FOR FUTURE BOARD CONSIDERATION**

Director Ruddock stated that she would like to see a report at the August or the September Board meeting on preparations for winter storms.

## **9. CONVENE IN CLOSED SESSION** *(Items discussed in Closed Session comply with The Ralph M. Brown Act)*

The Board went in to Closed Session at 7:32 p.m.

## **10. CONVENE IN OPEN SESSION**

The Board came out of Closed Session at 7:42 p.m. There was no reportable action.

**11. ADJOURNMENT**

Chair Slater-Carter adjourned the meeting at 7:42 p.m.

Respectfully Submitted,

Approved By:

---

Suzie Turbay  
Administrative Assistant

---

Board Secretary





**SEWER AUTHORITY MID-COASTSIDE**

**Staff Report**

**TO:** Honorable Board of Directors  
**FROM:** Tim Costello, Plant Superintendent  
**DATE:** July 24, 2023  
**SUBJECT:** **Monthly Manager’s Report – June 2023**

**Executive Summary**

The purpose of this report is to keep the Board and public informed of SAM’s day-to-day operations.

**Fiscal Impact**

There is no fiscal impact from this report.

**Strategic Plan Compliance**

The recommendation complies with the SAM Strategic Plan Goal 5.5: *“Operations and maintenance should be proactively planned, and the Board shall be kept up to date on progress on operations and maintenance issues.”*

**Background and Discussion/Report**

The following data is presented for the month of *June 2023*.

*Key Indicators of Performance*

NPDES Permit Violations: 0  
 Accidents, Injuries, etc.: 0  
 Reportable Spills Cat 1: 0  
 Reportable Spills Cat 2: 0  
 Reportable Spills Cat 3: 0  
 Reportable Spills Cat 4: 0

*Flow Report (See Attachment A)*

Half Moon Bay	0.809	61.19%
Granada CSD	0.260	19.71%
Montara W&SD	0.252	19.10%
<b>Total</b>	<b>1.321</b>	<b>100%</b>

<b>BOARD MEMBERS:</b>	M. Clark	B. Dye	P. Dekker
	D. Penrose	D. Ruddock	K. Slater-Carter
<b>ALTERNATE MEMBERS:</b>	S. Boyd	B. Softky	J. Randle
	J. Grant	H. Rarback	

**Administration**

There was one Regular Board Meeting in the month of June, and no public records request. There were four articles in the Half Moon Bay Review mentioning SAM, We Need SAM Leaders who see problems to be fixed (June 7, 2023), Midcoast Sewer Infrastructure needs real leadership (June 7, 2023), Sewer Authority Waits for Budget Approval (June 14, 2023), and GCSD Approves Operations, Sewer Budget (June 21, 2023). There were two mentions of SAM in Coastside Buzz, SAM Inter-tie Lawsuit Lumbers Along ~ Judge Currently Scheduled to Hear Oral Arguments in October with a Decision in 6 Months (June 15, 2023), and SAM Board Continues to Disagree on 2023/2024 Budget as Staff Warns of Violations, Criminal Charges and Plant Closure (June 29, 2023). There has been no lost time work accidents since September 10, 2019. There were no new hires in the month of June, and one anniversary, David Partida, Operator Grade III, 16 Years.

**Operations & Maintenance**

The following permanent flow storage installations are in place and functioning properly.

Montara Pump Station – Walker Tank, which has a capacity of 434,000 gallons.

The Portola Station – Wet Weather Facility, which has a capacity of 400,000 gallons.

The Portola Pump Station has the ability to use the Wet Weather Facility as a modified equalization basin if needed, (without mixing it is not ideal for this use). It is better suited as a wet weather flow storage as originally designed.

We continue to use sodium hydroxide for PH adjustment along with Alum, (aluminum chloride) and polymer to aid in settling in the secondary clarifier. These are being added at the back end of the MLSS basin and then carried by gravity to the secondary clarifier. We are adding polymer and cl2 for foam control on an as needed basis on the front side of the MLSS basin as well.

We continue to keep open communicating going with Mr. Burrell so that he is aware of any issues we might be experiencing.

In the beginning of the month we had the field staff go through SSO training and review of the new SERP (Sewer Emergency Response Training, this is an annual training we do). We also reviewed changes on the WDR (waste discharge requirements). One of the new things will be the new category 4 SSO's that you will see on the collections data going forward, at category 4 SSO's would be all spills below 50 gallons that were a

---

BOARD MEMBERS:	M. Clark	B. Dye	P. Dekker
	D. Penrose	D. Ruddock	K. Slater-Carter
ALTERNATE MEMBERS:	S. Boyd	B. Softky	J. Randle
	J. Grant	H. Rarback	

result of a main line stoppage. Also on the training side of things we had staff go through Lock out / tag out safety training with Du-all.

The influent bar screen project construction started at the beginning and was complete by the end of the month. It was brilliant orchestration of contractor, electrical contractor, engineering, project management and SAM staff to pull off this project in record time and completing the project by the end of the month. We should see a reduction of rags and plastics getting into the treatment train as a result and a reduction of equipment down time as a result due to rag related stoppages.

Half way through the month we did have a rag related issue with one of the primary drive chain drives. Staff was able to take down the primary remove the rags that caused the issue and restore the primary so that is ready to put back in service. Currently it is empty as we will likely use it to store flow when we start up aeration basin number 4. We need to stop flow through the facility as part of this project. To elaborate on this we need to stop flow through the treatment train so that we can jump in channel at the back end of aeration basin's 1 & 2 and install two mechanical plugs. The channels have to be empty to accomplish this task and we only have a short amount of time to make it happen.

RF MacDonald was called in to work on the boiler that failed, not the ideal situation as are other boiler is not really available for use. We are working on the replacement boilers but these are not off the shelf items.

We did have a chlorine exceedance while performing a cleaning task on the influent wet well. It's not a violation of the permit due to the magnitude but it still is a bummer and has to be reported regardless. If we had a larger wet well or an EQ basin this most likely would not have happened. I do have some thoughts on how best to prevent this going forward we just need to figure out how to make it happen.

Annual fire extinguisher inspections occurred at the end of the month. The goats were brought to the property at the end of the month as well for weed abatement. We should see the biological report from SWCA in the near future.

During the month of June 2023 rainfall was slightly below historic normal for Half Moon Bay. The 10-year average for the area is 0.148 inches of rain in June, (0.28 inches is considered to be normal, this year we received 0.20 inches, above the 10 year average

---

BOARD MEMBERS:	M. Clark	B. Dye	P. Dekker
	D. Penrose	D. Ruddock	K. Slater-Carter
ALTERNATE MEMBERS:	S. Boyd	B. Softky	J. Randle
	J. Grant	H. Rarback	

but slightly below what is considered normal). This web link has some very useful data for our area, <https://ggweather.com/hmb/>. Rainfall totals were as follows: 0.20 inches, (from the NOAA gauge at the plant). Our roof top had 0.29 at the plant, 0.16 inches in the GCSD service are, and 0.16 inches at the MWSD weather station. There were micro-climate variations verified by the data.

**Below is a chronological summary of some of the occurrences during the month of June 2023.**

- 6/1/2023 – Daily ops rounds and duties. Add chemicals to MLSS effluent. Clean contact basin #1. Clean and net out influent wet well.
- 6/2/2023 – Daily ops rounds and routine. Add chemicals to MLSS effluent. Neuros blower #1 not working properly, found surge valve no closing. All staff Training for SSO & WDR.
- 6/3/2023 – Saturday- Daily ops rounds and duties. Replace and fill up a couple polymer totes. Add chemicals to MLSS effluent. Increase sludge transfer to digester timers.
- 6/4/2023 – Sunday- Daily ops rounds and duties. Add chemicals to MLSS eff. Normal day nothing unusual.
- 6/5/2023 – Daily ops rounds and duties. TNT Company working on old bar screen demolition. Wash down headwork’s area where contractors will be working. CALCON here working on electrical equipment. Removed Sentry COD probes because of work being done. Boiler #2 fail reset all ok. Late in evening cleaned bar screen manually.
- 6/6/2023 – Daily ops rounds and duties. Add chemicals to MLSS. TNT Company working on bar screen demo. A few alarms were set off due to work being done at bar screens some live wires were found, CALCON was called to assist with diagnostic. Primary tank CEPT polymer pump not pumping removed cleaned and replace. Weekly inventory of plant chemicals. Manually clean bar screen late at night.
- 6/7/2023 – Daily ops rounds and duties. TNT Company here working on installing new bar screens. Collect quarterly samples and send to alpha labs. CALCON here working on electrical equipment. Lock out Tag Out training to all staff. Manually clean bypass bar screen late at night.
- 6/8/2023 – Daily ops rounds and duties. TNT Company here installing new bar screens. Manually clean bypass bar screen throughout the day. Clean

---

BOARD MEMBERS:	M. Clark	B. Dye	P. Dekker
	D. Penrose	D. Ruddock	K. Slater-Carter
ALTERNATE MEMBERS:	S. Boyd	B. Softky	J. Randle
	J. Grant	H. Rarback	

contact basin #2. Clean chemical tank filters. CALCON here working on electrical equipment. Operator at plant to clean bar screen at night.

- 6/9/2023 – Daily ops rounds. TNT Company working on bar screen installation. CALCON here working on electrical equipment. Hypochlorite Pump feed line has a small leak at the strainer housing, switch to bypass line. Pacific Forklift Company here working on forklift (maintenance). Polymer delivery at plant.
- 6/10/2023 – Saturday- Daily ops rounds. Rake bar screen throughout the day. Replace and fill a couple polymer totes. Add chemicals to MLSS effluent. Daily duties.
- 6/11/2023 – Sunday- Daily ops rounds. Add chemicals to MLSS effluent. Rake bar screens throughout the day. Nothing unusual.
- 6/12/2023 – Daily ops rounds and duties. Add chemicals to MLSS effluent. TNT Company working on new bar screens. CALCON working on electrical. Rake bar screen throughout the day.
- 6/13/2023 – Daily ops rounds. Safety tailgate training. TNT Company working on new bar screens. CALCON working on electrical. Add chemicals to MLSS effluent. Ops meeting regarding Aeration Basin #4. Rake bar screen throughout the day.
- 6/14/2023 – Daily ops rounds and duties. CALCON working on electrical equipment. All staff meeting with general manager. Hypochlorite delivery. Add chemicals to secondary. Rake bar screen throughout the day.
- 6/15/2023 – Daily ops rounds and duties. CALCON here working on electrical equipment. Rake bar screen throughout the day. Add chemicals to secondary. Sodium Bisulfite delivery to the plant. Cross collector for primary #1 found broken, quickly switched to primary #3, mechanics looking into fixing issue with primary #1.
- 6/16/2023 – Daily ops rounds and duties. CALCON here at the plant working on electrical equipment. Move 4" trash pump from influent well area to contact basin #1. Maintenance crew working on check valve for grit pump #1. Rake bar screen throughout the day.
- 6/17/2023 – Saturday- Daily ops rounds and duties. Blower #1 Failed early in the morning, Core 1 failed due to heavy vibration, reset blower 1 but Switched to Blower 2. Rake bar screen throughout the day. Plug in 2" pump and continue pumping down primary #1. Gas flare fail alarm, noticed gas

---

BOARD MEMBERS:	M. Clark	B. Dye	P. Dekker
	D. Penrose	D. Ruddock	K. Slater-Carter
ALTERNATE MEMBERS:	S. Boyd	B. Softky	J. Randle
	J. Grant	H. Rarback	

pressure was high due to high digester sludge tank level. Increased sludge transfer rate to lower level.

- 6/18/2023 – Sunday- Daily ops rounds and duties. Rake bar screen. Add chemicals to MLSS effluent. Collect Alpha samples. Princeton pump station pump 1 fault, found over current VFD, reset alarm and worked ok.
- 6/19/2023 – Boiler #2 failed in the early morning, tried resetting a few times but would not work, switched to Boiler #1. Call RF Mc Donald to look into Boiler 2. Add chemicals to MLSS effluent. Perform Confined space at primary #1 to inspect and clean cross collector. CALCON here working on New bar screen electrical equipment.
- 6/20/2023 – Daily ops rounds and duties. Add chemicals to MLSS effluent. Rake bar screen throughout the day. CALCON here working on new bar screens.
- 6/21/2023 – Daily ops rounds and duties. Add chemicals to MLSS effluent. CALCON here working on electrical for new bar screens. Rake bar screen throughout the day.
- 6/22/2023 – Daily ops rounds. CALCON working on electrical for DUPERON bar screens. Switch chemical pumps that feed plant process. Clean contact basin #1. Clean both aeration basin DO probes. Discuss new boiler design with RF McDonald and air quality folks. Boiler #1 failed late at night, reset the alarm and worked ok.
- 6/23/2023 – Daily ops rounds and duties. RF Mc Donald here working on boiler #2. Rake bar screen throughout the day. Add chemicals to MLSS effluent. CALCON here working on electrical equipment. DEOX analyzer chemical jug leaking, threaded nipple broke, replaced the jug with spare.
- 6/24/2023 – Saturday – Single operator on shift - Daily ops rounds. Add chemicals to MLSS effluent. Rake bar screen throughout the day. Daily duties.
- 6/25/2023 – Sunday – Single operator on shift - Daily ops rounds and duties. Add chemicals to MLSS effluent. Rake bar screens. Nothing unusual.
- 6/26/2023 – Daily ops rounds and duties. CALCON here to work on new bar screens. TNT here to work on bar screens. Remove gates to new bar screen unit and put new bar screens on service. Add chemicals to MLSS effluent.
- 6/27/2023 – Daily ops rounds and duties. Add chemicals to MLLS effluent. DUPERON here working on programming of new bar screen also presentation to operations and maintenance staff. Start collecting fire extinguishers for annual inspection. Replace and fill a few mixed polymer totes.

---

BOARD MEMBERS:	M. Clark	B. Dye	P. Dekker
	D. Penrose	D. Ruddock	K. Slater-Carter
ALTERNATE MEMBERS:	S. Boyd	B. Softky	J. Randle
	J. Grant	H. Rarback	

- 6/28/2023 – Daily ops rounds and duties. Add chemicals to MLSS effluent. Clean contact basin #2. Adjust mixing timer for CEPT polymer tote. Replaced container holding the secondary sampler. Clean and bleach final effluent sampler. Finish collecting all fire extinguishers. Simms plumbing came by to get a parts list together to put lower bathroom back together. Met with John from Andreini to look at a way to shore up the SW corner of the plant to help prevent the flooding issues we experienced earlier this year.
- 6/29/2023 – Daily ops rounds. Add chemicals to MLLS effluent. Clean and net out grease form influent wet well. While cleaning the influent well the level rose too high which backed up inflow in the head works. Also while pumping down the well too fast, it caused the mid plant flow to rise which in return caused the chemicals to increase but the de-chlorinator (bisulfite) could not keep up which resulted in high total chlorine residual. Although not violation it is considered goal exceedance and still reportable. Fire extinguisher annuals being performed by Pacific Fire safe. Perimeter fence set up for weed abatement on front property by Star Creek land stewards along with a biologist from SWCA. The goats will be moved into property tomorrow morning.
- 6/30/2023 – Daily ops rounds and duties. Add chemicals to MLSS effluent. Print all process graphs for month of JULY. Deliver and position back all fire extinguishers. Clean primary sampler jug and tubing.

**Other activities are listed below:**

There were 5 deliveries (approximately 3,650 gallons) of trucked waste discharged at the SAM Plant for a total revenue of \$ 365.00. There were no leachate deliveries to the SAM IPS line in the month of June 2023, for a total leachate volume of 0 gallons.

The NPDES data report for June 2023 is attached reference (Attachment B).

**Contract Collection Services**

The SAM crew cleaned 26,943 feet of sewer line and responded to thirteen service calls in contract service areas. Eight were sewer line related and five were maintenance service calls. Six of the callouts were during regular business hours or started during regular business hours. The other seven were after hour calls. Four calls were in HMB, nine calls were in the MWSD service area, and there were no calls in the GCSD service area during the month of June 2023.

---

BOARD MEMBERS:	M. Clark	B. Dye	P. Dekker
	D. Penrose	D. Ruddock	K. Slater-Carter
ALTERNATE MEMBERS:	S. Boyd	B. Softky	J. Randle
	J. Grant	H. Rarback	

HMB – The service calls in HMB was as follows; 6/8 - New e-box was received for smart cover. Installed e-box and stashed system. Functioning as it should again.

The maintenance calls in HMB were as follows; 6/3 - Call for Bell Moon station trouble. Station was working upon arrival. Cleared alarms and tested pumps, Observed station for normal operation. 6/14 - Pelican point station alarm. Found station operating normal upon arrival. Genny did not run, cleared alarms and checked station for normal operation. 6/26 - Pelican point station alarm. Station fault, pump 2, Genny alarm, power fail alarm. Reset alarms, observed station operating normally. Cleaned station antenna connection for a better signal.

GCSD – There were no sewer line service calls in the GCSD in the month of June of 2023

There were no maintenance service calls in the GCSD service area in the month of June 2023.

MWSD – The sewer line related call in the MWSD area was as follows; 6/6 - Smart cover alarm at Date and Cedar. Crew flushed main to remove rag build up in manhole. District is aware that there is an issue with bench and trough in the manhole that builds up debris. 6/12 – Smart cover alert for delayed communications. Replacement e-box was ordered and will be replaced once it comes in. 6/23 – Call for a slow lateral. When the crew arrived they observed that the main was flowing but flushed it for precautionary measures. The service line was still slow, advised homeowner to follow up with a plumber. 6/24 – MWSD staff called as they noticed water from the genny building, crew arrived and found toilet vale stuck and running. We are likely going to replace the toilet in the genny room as the toilet internals are funky. 6/25 – Call for water running down the street. When the crew arrived that found a leaking water valve to be the issue. Crew made contact with district staff to make sure they were aware of the issue. Valve is in the process of being repaired. 6/28 - Smart cover alert for delayed communications. Replacement e-box was ordered and will be replaced once it comes in. Checked with smart cover folks, they said it was ordered and should be here soon. 6/30 - Call for service line leaking. Crew flushed

---

BOARD MEMBERS:	M. Clark	B. Dye	P. Dekker
	D. Penrose	D. Ruddock	K. Slater-Carter
ALTERNATE MEMBERS:	S. Boyd	B. Softky	J. Randle
	J. Grant	H. Rarback	



main and found no obstruction. Employee from establishment snaked service line to clear their blockage that was in the service line.

The maintenance calls in the MWSD service area were as follows; 6/19 - Call for lateral backup, house is on grinder. Unable to locate grinder lid at first as it was landscaped over. Once located found two issues, one with wiring and the other with the discharge pipe. Both issues resolved now, operating as normal. 6/27 - Seal cove 2 low battery alarm on dialer. Replaced dialer battery, cleared alarms, checked station for normal operation.

The June 2023 collection system data report is provided for the Board's information. There were Zero (0) Category 1, Zero (0) Category 2's, Zero (0) Category 3's, and Zero (0) category 4 SSO's, during the month of June 2023. \*\*note that the category 4 is new effective this month, (0 to 49 gallons).

**Staff Recommendation**

Staff recommends that the Board receive the Manager's Report for June 2023.

**Supporting Documents**

Attachment A: Monthly Flow Report June 2023

Attachment B: Monthly NPDES Report June 2023

Attachment C: Collection System Data June 2023

Attachment D: Contract Collection Service Report June 2023

---

BOARD MEMBERS:	M. Clark	B. Dye	P. Dekker
	D. Penrose	D. Ruddock	K. Slater-Carter
ALTERNATE MEMBERS:	S. Boyd	B. Softky	J. Randle
	J. Grant	H. Rarback	

# Attachment A

## Flow Distribution Report Summary for June 2023

The daily flow report figures for the month of June 2023 have been converted to an Average

Daily Flow (ADF) for each Member Agency.  
The results are attached for your review.

The summary of the ADF information is as follows:

	<u>MGD</u>	<u>%</u>
The City of Half Moon Bay	0.809	61.19%
Granada Community Services District	0.260	19.71%
Montara Water and Sanitary District	<u>0.252</u>	<u>19.10%</u>
Total	1.321	100.0%

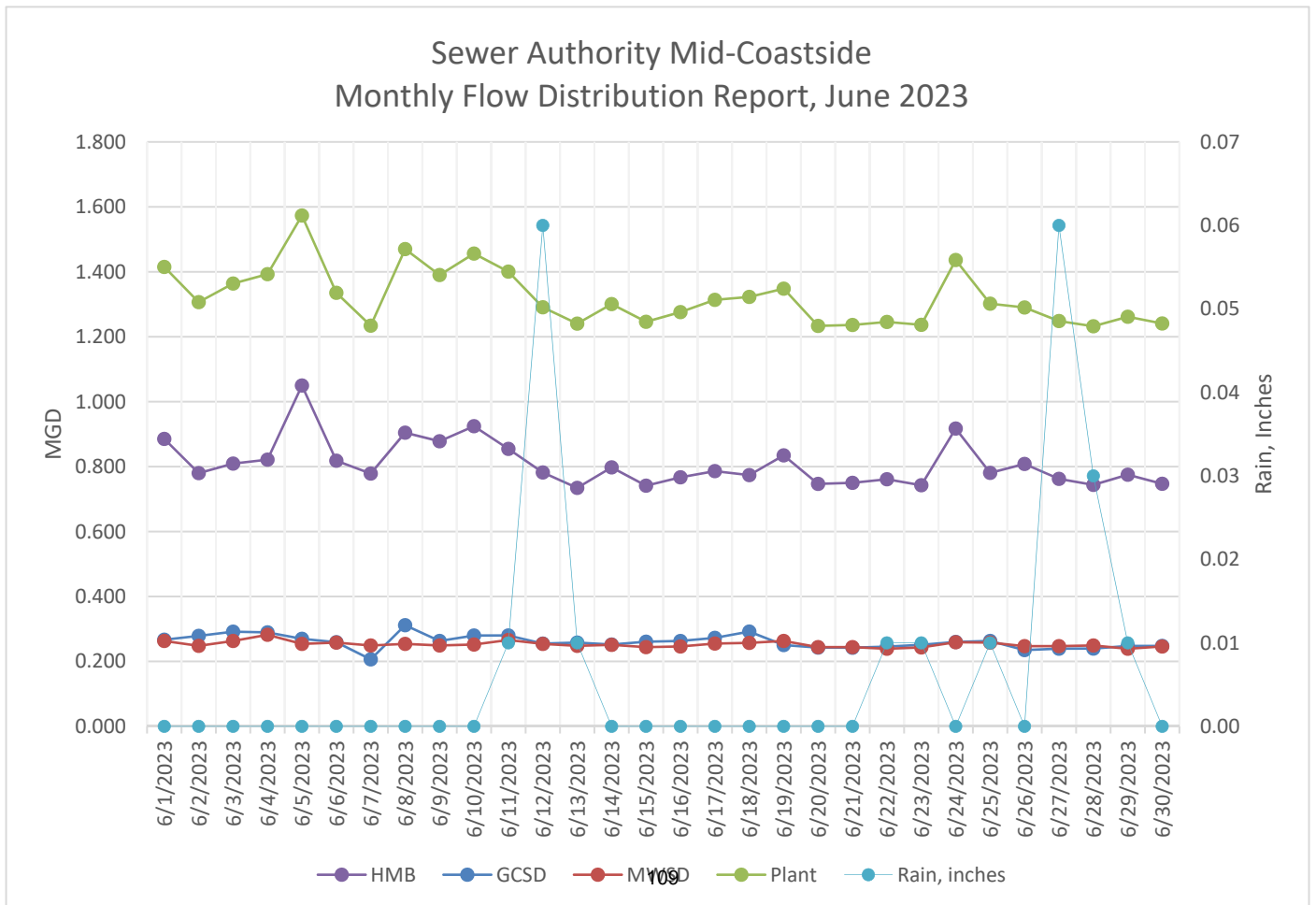

**SAM E-001 June 2023**

Date	Inf TSS mg/l	Eff TSS mg/l	Eff TSS Weekly Avg	TSS % Removal	Inf BOD mg/l	I° Eff BOD mg/l	Eff BOD mg/l	Eff BOD Weekly Avg mg/l
6/1/2023								
6/2/2023								
6/3/2023								
6/4/2023								
6/5/2023								
6/6/2023	320	9.80		96.9%	200	160	8.7	
6/7/2023	280	7.70		97.3%	230	190	5.8	
6/8/2023								
6/9/2023								
6/10/2023			8.75					7.25
6/11/2023								
6/12/2023								
6/13/2023								
6/14/2023	260	5.80		97.8%	220	180	14.0	
6/15/2023	290	5.20		98.2%	220	170	11.0	
6/16/2023								
6/17/2023			5.50					12.50
6/18/2023	340	7.10		97.9%	170	140	11.0	
6/19/2023	250	8.40		96.6%	250	200	11.0	
6/20/2023								
6/21/2023								
6/22/2023								
6/23/2023								
6/24/2023			7.75					11.00
6/25/2023								
6/26/2023	300	5.80		98.1%	260	200	11.0	
6/27/2023	310	6.80		97.8%	240	170	17.0	
6/28/2023								
6/29/2023								
6/30/2023								
			6.30					14.00
Count	8	8	4	8	8	8	8	4
Minimum	250	5.20	5.50	96.6%	170	140	5.8	7.3
Average	294	7.08	7.08	97.6%	224	176	11.2	11.2
Maximum	340	9.80	8.75	98.2%	260	200	17.0	14.0
Percent Removal				85				
5 Sample Median								
High								
Low								
Daily Max								
Weekly Max			45					45
Monthly Average		30					30	

**SAM E-001 June 2023**

<b>Date</b>	<b>BOD % Removal</b>	<b>Eff Settleeable Matter mg/l</b>	<b>Eff Settleeable Matter Weekly Avg mg/l</b>	<b>Eff Turbidity NTU</b>	<b>Eff Turbidity Weekly Avg NTU</b>	<b>Chlorine Residual Day Max</b>
6/1/2023						0.00
6/2/2023						0.00
6/3/2023						0.00
6/4/2023						0.00
6/5/2023						0.00
6/6/2023	95.7%	ND		2.10		0.00
6/7/2023	97.5%	ND		4.00		0.00
6/8/2023						0.00
6/9/2023						0.00
6/10/2023			ND		3.05	0.00
6/11/2023						0.00
6/12/2023						0.00
6/13/2023						0.00
6/14/2023	93.6%	ND		2.00		0.00
6/15/2023	95.0%	ND		1.40		0.00
6/16/2023						0.00
6/17/2023			ND		1.70	0.00
6/18/2023	93.5%	ND		0.75		0.00
6/19/2023	95.6%	ND		0.05		0.00
6/20/2023						0.00
6/21/2023						0.00
6/22/2023						0.00
6/23/2023						0.00
6/24/2023			ND		0.40	0.00
6/25/2023						0.00
6/26/2023	95.8%	ND		1.30		0.00
6/27/2023	92.9%	ND		1.40		0.00
6/28/2023						0.00
6/29/2023						1.69
6/30/2023						0.00
			ND		1.35	0.00
Count	8	0	0	8	4	31
Minimum	92.9%	0.0	< 0.00	0.05	0.40	0.0
Average	94.9%	#DIV/0!	#DIV/0!	1.63	1.63	0.1
Maximum	97.5%	0.0	0.0	4.00	3.05	1.7
Percent Removal	85					
5 Sample Median						
High						
Low						
Daily Max				225		4.8
Weekly Max					100	
Monthly Average				75		

**SAM      E-001      June 2023**

Date	Chlorine time Minutes	Ammonia Nitrogen Distilled mg/l	Eff pH	Eff Temp	Enterococci MPN	30 day geo mean	Eff DO mg/l	Eff DO % Saturation
6/1/2023	0.00		7.04	19.1			7.08	76.4
6/2/2023	0.00		7.12	19.4			7.10	77.0
6/3/2023	0.00		7.10	19.7		< 5.743	7.69	84.1
6/4/2023	0.00		7.06	19.4			7.50	81.4
6/5/2023	0.00		7.17	19.4			7.33	79.6
6/6/2023	0.00		7.17	19.5			7.62	82.7
6/7/2023	0.00	17.0	7.18	19.3	ND		7.77	84.3
6/8/2023	0.00		7.06	19.6			7.57	82.5
6/9/2023	0.00		7.20	19.9			7.37	80.7
6/10/2023	0.00		7.15	20.0		< 5.743	7.66	83.7
6/11/2023	0.00		6.95	19.3			6.64	71.8
6/12/2023	0.00		7.18	19.6			7.37	80.4
6/13/2023	0.00		6.91	20.1			7.27	79.7
6/14/2023	0.00		7.00	19.8			7.01	76.8
6/15/2023	0.00	17.0	6.98	20.1	ND		6.99	76.9
6/16/2023	0.00		7.12	20.3			7.33	81.0
6/17/2023	0.00		7.10	20.3		ND	7.51	82.9
6/18/2023	0.00		7.09	19.8			6.96	76.1
6/19/2023	0.00	8.0	7.20	20.0	ND		7.22	79.3
6/20/2023	0.00		7.08	19.6			6.95	75.8
6/21/2023	0.00		7.04	19.8			6.74	73.9
6/22/2023	0.00		7.13	20.3			7.73	85.4
6/23/2023	0.00		7.00	19.8			7.42	81.2
6/24/2023	0.00		7.04	19.9		ND	7.34	80.4
6/25/2023	0.00		7.02	20.2			6.76	74.6
6/26/2023	0.00		7.17	20.1			7.41	81.6
6/27/2023	0.00	12.0	7.08	19.4	ND		7.07	76.7
6/28/2023	0.00		7.17	19.5			7.90	88.8
6/29/2023	6:25		7.00	19.8			6.63	72.4
6/30/2023	0.00		7.03	20.0		ND	7.23	79.5
	0.00							
Count	30	4	30	30	0	2	30	30
Minimum	0.00	8.0	6.91	19.1	< ND	< ND	6.63	71.8
Average	0.0	13.5	7.08	19.8	< ND	< 5.743	7.27	79.6
Maximum	0.00	17.0	7.20	20.3	0	< 5.7	7.90	88.8
Percent Removal								
5 Sample Median						2,800		
High			9					
Low			6					
Daily Max					8,300			
Weekly Max								
Monthly Average								

# Sewer Authority Mid-Coastside

## Monthly Collection System Activity/SSO Distribution Report, June 2023

**June 2023**

	<b>Total</b>	<i>Number of S.S.O's</i>			
		<b>HMB</b>	<b>GCS D</b>	<b>MWSD</b>	<b>SAM</b>
Roots	0	0	0	0	0
Grease	0	0	0	0	0
Mechanical	0	0	0	0	0
Wet Weather	0	0	0	0	0
Other	0	0	0	0	0
<b>Total</b>	<b>0</b>	<b>0</b>	<b>0</b>	<b>0</b>	<b>0</b>

**12 Month Moving Total**

	<b>Total</b>	<i>12 month rolling Number</i>			
		<b>HMB</b>	<b>GCS D</b>	<b>MWSD</b>	<b>SAM</b>
Roots	3	0	1	2	0
Grease	0	0	0	0	0
Mechanical	2	0	0	0	2
Wet Weather	10	4	0	2	4
Other	1	1	0	0	0
<b>Total</b>	<b>16</b>	<b>5</b>	<b>1</b>	<b>4</b>	<b>6</b>
		<b>31%</b>	<b>6%</b>	<b>25%</b>	<b>38%</b>

**Reportable SSOs**

	<b>Total</b>	<i>Reportable Number of S.S.O.'s</i>			
		<b>HMB</b>	<b>GCS D</b>	<b>MWSD</b>	<b>SAM</b>
June 2023	0	0	0	0	0
12 Month Moving Total	16	5	1	4	6

**SSOs / Year / 100 Miles**

	<b>Total</b>	<i>Number of S.S.O.'s /Year/100 Miles</i>			
		<b>HMB</b>	<b>GCS D</b>	<b>MWSD</b>	<b>SAM</b>
June 2023	0.0	0.0	0.0	0.0	0.0
12 Month Moving Total	15.3	13.5	3.0	14.8	82.2
Category 1	6.7	0.0	0.0	3.7	82.2
Category 2	3.8	10.8	0.0	0.0	0.0
Category 3	4.8	2.7	3.0	11.1	0.0
Category 4	0.0	0.0	0.0	0.0	0.0
Miles of Sewers	104.5	37.0	33.2	27.0	7.3
		<b>35.4%</b>	<b>31.8%</b>	<b>25.8%</b>	<b>7.0%</b>

**12 Month Rolling Total Sewer Cleaning Summary**

Month	HMB	GCS D	MWSD	Total Feet	Total Miles
July - 22	8,472	12,491	4,718	25,681	4.9
Aug - 22	15,041	7,358	11,197	33,596	6.4
Sep - 22	11,786	11,227	4,455	27,468	5.2
Oct - 22	12,220	8,847	9,308	30,375	5.8
Nov - 22	17,708	10,924	9,483	38,115	7.2
Dec - 22	2,384	9,393	5,101	16,878	3.2
Jan - 23	6,748	10,481	8,748	25,977	4.9
Feb - 23	14,417	9,983	6,822	31,222	5.9
Mar - 23	12,243	9,395	10,140	31,778	6.0
Apr - 23	10,883	12,375	8,290	31,548	6.0
May - 23	12,239	11,619	5,356	29,214	5.5
June - 23	11,096	10,472	5,375	26,943	5.1

Annual ft	135,237	124,565	88,993	348,795	
-----------	---------	---------	--------	---------	--

Annual Mi.	25.6	23.6	16.9		66.1
------------	------	------	------	--	------

Attachment C

**12 Month Moving SSO Totals Through June 2023**

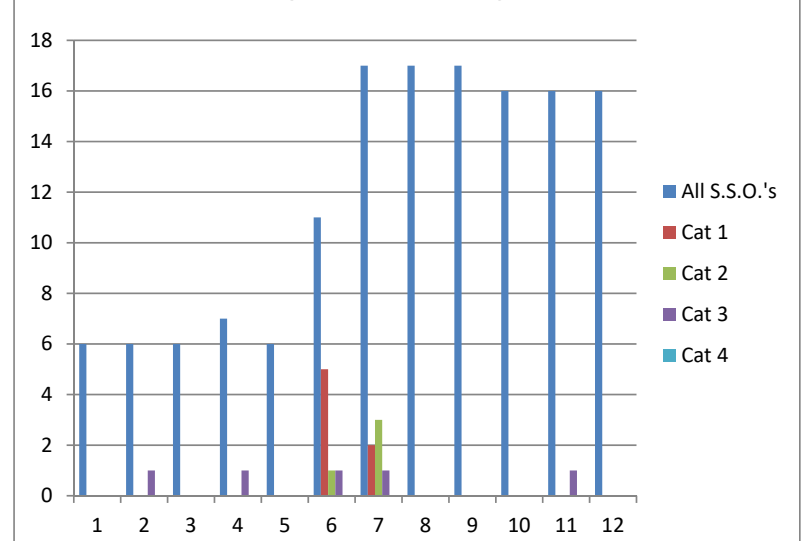

## TASK SUMMARY- GCSD 2022-2023

Task	Target Total	Jul	Aug	Sept	Oct	Nov	Dec	Jan	Feb	March	April	May	June	Total to Date	% Complete
Sewer Line Cleaning	87,000	11,681	7,015	10,109	8,235	7,057	8,660	7,235	7,943	7,244	11,694	5,800	9,786	102,459	118%
Hot Spot Cleaning	5,400	-	2,038	530	602	986	1,382	407	2,691	2,801	730	1,450	-	13,617	252%
Lift Station Inspection - Daily	52	4	5	4	4	4	5	5	4	5	4	4	4	52	100%
Lift Station Inspection - Annually	3	-	-	-	-	-	-	-	-	-	-	-	-	-	0%
Maint. Work Orders - Completed	-	4	5	4	4	4	5	5	4	5	4	4	4	52	
Maint. Work Orders - Incomplete	-	-	-	-	-	-	-	-	-	-	-	-	-	-	
Manhole Inspection	879	55	43	56	50	49	51	50	66	63	70	62	48	663	75%
USA Markings	372	103	225	82	137	83	86	76	57	95	59	66	70	1,139	306%
F.O.G. Inspections Completed	10	-	-	-	-	-	-	-	-	-	-	-	-	-	0%
F.O.G. Inspections Passed	10	-	-	-	-	-	-	-	-	-	-	-	-	-	0%
F.O.G. Inspection Failed	-	-	-	-	-	-	-	-	-	-	-	-	-	-	
Lateral Inspections	-	-	-	-	-	-	-	-	-	-	-	-	-	-	
Customer Service Call - Reg	-	3	1	1	4	-	4	-	3	4	2	2	-	24	
Customer Service Call - OT	-	1	2	2	3	1	-	2	1	1	2	-	-	15	
SSO Response - Category 1	-	-	-	-	-	-	-	-	-	-	-	-	-	-	
SSO Response - Category 2	-	-	-	-	-	-	-	-	-	-	-	-	-	-	
SSO Response - Category 3	-	-	1	-	-	-	-	-	-	-	-	-	-	1	
Insurance Claims Filed	-	0	0	0	0	0	0	0	0	0	0	0	0	-	

**ITEM #9**



Blank



## GRANADA COMMUNITY SERVICES DISTRICT

# MINUTES BOARD OF DIRECTORS REGULAR MEETING

July 20, 2023 at 7:30 p.m.

**THIS MEETING WAS HELD IN PERSON AND VIA ZOOM.**

### **CALL REGULAR MEETING TO ORDER**

The Regular Meeting was called to order at 7:31 pm.

### **ROLL CALL**

President Nancy Marsh, Vice President Jen Randle, Director Matthew Clark. Director Barbara Dye and Director Jill Grant participated remotely via teleconference.

Staff: General Manager Chuck Duffy, Assistant General Manager Delia Comito, Assistant General Manager Hope Atmore and District Counsel William Parkin.

### **GENERAL PUBLIC PARTICIPATION**

None.

### **REGULAR MEETING AGENDA**

#### **1. Parks and Recreation Activities.**

##### **a. Report on Granada Community Park and Recreation Center.**

Project Manager Ray Razavi updated board and staff on the project description being developed for the CEQA and permitting work, potential grants, procurement of irrigation water, and the biological and cultural reviews.

##### **b. Consideration of Summer Recreation Program.**

Director Dye requested that staff schedule events for Fall to include nature and history walks and a possible adaptive bike outing.

#### **2. Report on Assessment District.**

Assistant General Manager Comito gave an overview of the Assessment District status now that the bonds have been paid off, and recommended that the board develop a budget and procedures going forward. Ms. Comito introduced Bond Counsel Cameron Weist for questions. Mr. Weist will develop the first draft of the assessment district procedures.

#### **3. Approval of Audited District Financial Statements for the Fiscal Year Ending June 30, 2022.**

President Marsh reported a correction to the listed Board of Directors as of June 30, 2022 and that this information was relayed to the auditor. Assistant General Manager Comito stated that the next audit will start in October.

**ACTION:** Director Clark moved to approve the Audited FY 2021/22 Financial statements. (Clark/Randle). Approved 5-0.

**4. Public Hearing: Consideration of a Resolution Adopting the Sewer Service Charge Report and Delinquent Garbage Account Report and Authorizing the Collection of Said Charges on the Fiscal Year 2023/24 San Mateo County Tax Roll.**

Board President Nancy Marsh opened the Public Hearing. There were no public comments. Staff stated that notice of Sewer Service Charge was properly noticed in the local newspaper and no written protest was submitted.

**ACTION:** Director Dye moved to approve the Resolution. (Dye/Clark). Approved 5-0.

**5. Approval of Sewer Authority Mid-Coastside Revised Fiscal Year 2023/24 General Budget (from June 26<sup>th</sup> SAM meeting) and Related Resolution.**

Director Dye reported that the Half Moon Bay City Council refused to approve a budget that would include the repairs to the Montara force main section of the SAM Intertie Pipeline. The new June 26<sup>th</sup> SAM budget includes preliminary design work for the Montara force main repairs, replacement of the plant emergency generator and the plant boilers. After mid-year, the SAM board agreed to revisit the SAM budget upon resolution of the lawsuit filed by Half Moon Bay against the other two member agencies.

**ACTION:** Director Dye moved to approve the revised June 26<sup>th</sup> SAM budget. (Dye/Grant). Approved 5-0.

**6. Engineer's Report.**

The District Engineer reported that the Phase 2 work for the District sewer main replacement program had been completed, and a Notice of Completion would need to be filed.

**7. Report on Sewer Authority Mid-Coastside Meetings.**

Director Dye reported SAM has exceeded its budget in some categories and is using reserves to cover shortfalls.

**8. Resolution Expressing Gratitude and Appreciation to Delia Comito.**

The Board of Directors and district staff commended Assistant General Manager Delia Comito's dedication to the District and thanked her for her years of service. Community Member Fran Pollard also congratulated Ms. Comito on her retirement.

**ACTION:** Director Clark moved to approve the resolution (Clark/Randle). Approved 5-0.

**CONSENT AGENDA**

**9. June 15, 2023 Special and Regular Meeting Minutes.**

**10. July 2023 Warrants.**

**11. May 2023 Financial Statements.**

**12. Assessment District Distribution #1-23/24.**

**ACTION:** Director Randle moved to approve the Consent Agenda. (Randle/Clark). Approved 5-0.

**COMMITTEE REPORTS**

**13. Report on seminars, conferences, or committee meetings.**

**INFORMATION CALENDAR**

**14. Attorney's Report. (Parkin)**

**15. General Manager's Report. (Duffy)**

**16. Administrative Staff Report. (Comito)** Assistant General Manager Comito reminded the board of the upcoming recycling drop off event. She also reported that the RV's parked at the Granada Community Park site had been stickered and had moved.

**17. Future Agenda Items.** Board President Marsh asked if the start time for future Regular Meetings could be addressed to start a half an hour earlier.

**ADJOURN REGULAR MEETING**

The regular meeting was adjourned at 9:14 p.m.

Date Approved by the Board: August 17, 2023.

ATTEST:

---

Hope Atmore, Board Secretary



# ITEM #10

Blank

**Granada Community Services District**  
**August 2023 Warrants**  
**For the August 17, 2023 Board of Director's Meeting**

<b>Date</b>	<b>Num</b>	<b>Name</b>	<b>Memo</b>	<b>Account</b>	<b>Amount</b>
07/20/23	9644	AT&T	Inv dtd 07/05/23	6170 · Utilities	318.58
07/20/23	9645	BKF Engineers	Park Engineering Svcs-Jun 2023	5130 · Parks & Rec Professional Svcs	1,531.00
07/20/23	9646	Candise D'Acquisto	480 Ave Alhambra-Bookshelf Reim	6135 · Other Property Maint	82.51
07/20/23	9647	Delia Comito	Mini Fridge Reim	6140 · Office Supplies	304.81
07/20/23	9648	Dudek	05/27/23-06/30/23 Prof Svcs	6151 · General Manager	9,845.00
07/20/23	9649	HMBTech4U	Inv dtd 07/09/23	6190 · Computers	150.00
07/20/23	9650	Hope Atmore	Office Desks-Reim	6140 · Office Supplies	1,420.71
07/20/23	9651	Hue & Cry, Inc	Aug 2023 Pump Stn Alarm	6170 · Utilities	38.59
07/20/23	9652	Kennedy Jenks	Jun 2023 Svcs, Sum 193	6070 · Engineering Services	6,016.40
07/20/23	9653	Peninsula Municipal Engineering	Inv dtd 07/19/23	5130 · Parks & Rec Professional Svcs	5,600.00
07/20/23	9654	Tri Counties Bank	Jun 2023 Card Charges	6140 · Office Supplies	887.83
07/20/23	9655	US Postal Service	PO Box Service Fee - 12 Months	6140 · Office Supplies	248.00
07/20/23	9656	Verizon Wireless	Jul 2023	6170 · Utilities	142.30
07/20/23	9657	Tom McGuirk	Refund of NDWSCP Fees Pd to SAM Blue Ocean Brew	2003 · Due to GCSD Customer	550.00
08/17/23	9658	Alhambra & Sierra Springs	Invoice dtd 08/03/23	6140 · Office Supplies	36.97
08/17/23	9659	Barbara Dye	07/20/23 GCSD	6040 · Directors' Compensation	145.00
08/17/23	9660	Brush Hog Tree Care Inc	Tree Removal GCSD Prop APN 048-046-120	6135 · Other Property Maint	950.00
08/17/23	9661	CJ Brown & Company CPAs	Prof Svcs through 07/31/23	6010 · Auditing	3,735.00
08/17/23	9662	CliftonLarsonAllen LLP	Jul 2023 Accounting Svcs	6152 · Accounting	3,234.00
08/17/23	9663	Comcast	08/13/23-09/12/23	6170 · Utilities	319.66
08/17/23	9664	Hope Atmore	Misc reimbursements	6050 · Education & Travel Reimb	1,909.90
08/17/23	9665	Horizon Water and Environment	Inv dtd 07/21/23	5130 · Parks & Rec Professional Svcs	3,293.04
08/17/23	9666	Hue & Cry, Inc	Sep 2023 Pump Stn Alarm	6170 · Utilities	35.59
08/17/23	9667	Jen Randle	07/20/23 GCSD	6040 · Directors' Compensation	145.00
08/17/23	9668	Jill Grant	07/20/23 GCSD	6040 · Directors' Compensation	145.00
08/17/23	9669	Kikuchi Kankel Design Group	Prof Svcs through 07/31/23	5130 · Parks & Rec Professional Svcs	5,932.50
08/17/23	9670	Matthew Clark	07/20/23 GCSD	6040 · Directors' Compensation	145.00
08/17/23	9671	Nancy Marsh	07/20/23 GCSD	6040 · Directors' Compensation	145.00
08/17/23	9672	Pacifica Community TV	07/20/23 GCSD	6180 · Video Taping	400.00
08/17/23	9673	PG&E	Office Inv dtd 07/25/23	6170 · Utilities	59.74
08/17/23	9674	PG&E	Pump Stn Inv dtd 07/18/23	6170 · Utilities	473.14
08/17/23	9675	Recology of the Coast	Del Garbage Pass-Thru 22/23 Tax Roll	2225 · Recology-Del Garbage	21,823.74
08/17/23	9676	Riordan Consulting	Jun 2023 IT Svcs	6190 · Computers	540.00
08/17/23	9677	Rodolfo Romero	Aug Cleaning	6130 · Office Maintenance & Repairs	180.00
08/17/23	9678	SMC Harbor District	Office Lease-Sep 2023	6120 · Office Lease	4,600.00
08/17/23	9679	Sewer Authority Mid-Coastside	Aug 2023 Asmts	5010 · SAM - General	135,649.61
08/17/23	9680	US Bank Equipment Finance	Aug 2023 Svcs	6020 · Copier lease	358.75
08/17/23	9681	Wittwer & Parkin	Jul 2023 Svcs	6090 · Legal Services	2,511.00
<b>TOTAL</b>					<b>\$ 213,903.37</b>





**ITEM #11**

Blank

**Granada Community Services District  
Statement of Net Position (Unaudited)  
As of June 30, 2023**

**ASSETS**

Current Assets

Checking/Savings

1020 · Petty Cash		\$	207
1030 · Cash - LAIF			3,435,060
1040 · Tri Counties Bank - Gen Op			24,686
1050 · Tri Counties Bank - Deposit			17,345

Total Checking/Savings			3,477,298
------------------------	--	--	-----------

Other Current Assets

1100 · Accounts Receivable			87,425
1200 · Interest Receivable			12,270
1550 · Prepaid Expenses			4,736

Total Other Current Assets			104,581
----------------------------	--	--	---------

Total Current Assets			3,581,879
----------------------	--	--	-----------

Fixed Assets

1600 · Land			2,862,979
1610 · Construction in Progress			1,155,954
1615 · Equipment			22,153
1620 · Collections System			11,659,302
1630 · Accumulated Depreciation			(7,825,452)

Total Fixed Assets			7,874,936
--------------------	--	--	-----------

Other Assets

1750 · Investment in SAM			4,708,434
1760 · Deferred Outflows of Resources			88,433

Total Other Assets			4,796,867
--------------------	--	--	-----------

Total Assets			16,253,682
--------------	--	--	------------

PRELIMINARY DRAFT

*(Continued on next page)*

**Granada Community Services District  
Statement of Net Position (Unaudited)  
As of June 30, 2023  
(Continued)**

**LIABILITIES**

Liabilities

Current Liabilities

Accounts Payable

2000 · Accounts Payable 91,475

2001 · Accrued Vacation 1,468

2003 · Due to GCSD Customer 550

2020 · Class 3 Deposits 19,055

2100 · Payroll Liabilities 3,017

2225 · Recology-Del Garbage 13,585

2300 · Due to AD 14,988

Total Current Liabilities 144,138

Long Term Liabilities

2401 · Net Pension Liability 86,607

2402 · Deferred Inflows of Resources 86,394

Total Long Term Liabilities 173,001

Total Liabilities 317,139

**NET POSITION**

3000 · Net Assets 15,456,553

Net Income 479,990

Total Net Position \$ 15,936,543

PRELIMINARY DRAFT

**Granada Community Services District  
Revenues & Expenses (Unaudited)  
July 1, 2022 through June 30, 2023**

	Jul 1, 2022 - Jun 30, 2023	Expected To Date	Variance Favorable/ (Unfavorable)	FY 2022/2023 Budget
<b>Revenues</b>				
Operating Revenue				
4015 · Park Tax Allocation	\$ 946,270	\$ 925,000	\$ 21,270	\$ 925,000
4020 · Sewer Service Charges-SMC	2,010,152	2,155,000	(144,848)	2,155,000
4021 · Sewer Svc Charges Pro-rated	2,018	-	2,018	-
4030 · AD OH Reimbursement	33,000	33,000	-	33,000
4040 · Recology Franchise Fee	48,803	41,000	7,803	41,000
4050 · Delinquent Garbage Fee	2,193	-	2,193	-
Total Operating Revenue	3,042,436	3,154,000	(111,564)	3,154,000
Non Operating Revenue				
4120 · Interest on Reserves	53,728	25,500	28,228	25,500
4121 · Interfund Loan Interest Revenue	144,584	-	144,584	-
4125 · Unrealized Gain (Loss) in LAIF	(17,366)	-	(17,366)	-
4130 · Connection Fees	154,630	28,000	126,630	28,000
4150 · Repayment of Adv to AD-NCA	-	315,000	(315,000)	315,000
4160 · SAM Refund from Prior Yr	-	1,000	(1,000)	1,000
4170 · ERAF Refund	463,211	350,000	113,211	350,000
4180 · Misc Income	3,373	6,000	(2,627)	6,000
4185 · Lease Revenue	61,000	60,000	1,000	60,000
Total Non Operating Revenue	863,160	785,500	77,660	785,500
Total Revenues	3,905,596	3,939,500	(33,904)	3,939,500
Gross Profit	3,905,596	3,939,500	(33,904)	3,939,500
<b>Expenses</b>				
Operations				
5010 · SAM - General	1,031,541	1,031,541	-	1,031,541
5014 · SAM - Pass Through Costs	4,185	-	(4,185)	-
5020 · SAM - Collections	209,400	209,400	-	209,400
5021 · Lift Station Maint.	191	-	(191)	-
5022 · SAM- NDWSCP	19,002	-	(19,002)	-
5040 · Depreciation Expense	275,000	-	(275,000)	-
5050 · Mainline System Repairs	-	10,000	10,000	10,000
5060 · Lateral Repairs	21,479	15,000	(6,479)	15,000
5065 · CCTV	-	10,000	10,000	10,000
5070 · Pet Waste Station	1,249	1,800	551	1,800
5110 · RCD - Parks	2,634	30,000	27,366	30,000
5120 · Half Moon Bay Reimb - Parks	28,184	109,800	81,616	109,800
5130 · Parks & Rec Professional Services	288,979	300,000	11,021	300,000
Total Operations	1,881,844	1,717,541	(164,303)	1,717,541

(Continued on next page)

No assurance is provided on these financial statements. See selected information.

**Granada Community Services District  
Revenues & Expenses (Unaudited)  
July 1, 2022 through June 30, 2023**

	Jul 1, 2022 - Jun 30, 2023	Expected To Date	Variance Favorable/ (Unfavorable)	FY 2022/2023 Budget
Expenses (Continued)				
Administration				
6010 · Auditing	11,840	22,000	10,160	22,000
6020 · Copier lease	5,152	6,000	848	6,000
6040 · Directors' Compensation	9,130	12,000	2,870	12,000
6050 · Education & Travel Reimb	757	2,000	1,243	2,000
6060 · Employee Compensation	357,207	390,000	32,793	390,000
6070 · Engineering Services	34,929	30,000	(4,929)	30,000
6080 · Insurance	47,182	35,000	(12,182)	35,000
6090 · Legal Services	86,520	32,000	(54,520)	32,000
6095 · Legal Services for Case Related Legal	-	30,000	30,000	30,000
6100 · Memberships	10,730	9,000	(1,730)	9,000
6120 · Office Lease	54,950	60,000	5,050	60,000
6130 · Office Maintenance & Repairs	2,533	2,500	(33)	2,500
6135 · Other Property Maint.	2,133	-	(2,133)	-
6140 · Office Supplies	7,467	2,500	(4,967)	2,500
6150 · Professional Services	132,924	136,000	3,076	136,000
6160 · Publications & Notices	5,077	15,000	9,923	15,000
6170 · Utilities	13,756	14,000	244	14,000
6180 · Video Taping	4,300	5,000	700	5,000
6190 · Computers	6,604	3,000	(3,604)	3,000
6220 · Miscellaneous	35,170	8,000	(27,170)	8,000
6230 · Bank Service Charges	303	-	(303)	-
6310 · Park Related Misc Expenses	113,427	130,000	16,573	130,000
<b>Total Administration</b>	<b>942,091</b>	<b>944,000</b>	<b>1,909</b>	<b>944,000</b>
Capital Projects				
1415-4 · 22/23 SSMP Costs	2,247	-	(2,247)	-
1617-1 · Medio Creek Xing Crossing	855	-	(855)	-
7013 · 6-yr CIP Phase 2	610,517	350,000	(260,517)	350,000
7100 · SAM - Infrastructure	598,569	598,569	-	598,569
Reclassified to Construction in Progress	(610,517)	-	610,517	-
<b>Total Capital Projects</b>	<b>601,671</b>	<b>948,569</b>	<b>346,898</b>	<b>948,569</b>
<b>Total Expenses</b>	<b>3,425,606</b>	<b>3,610,110</b>	<b>184,504</b>	<b>3,610,110</b>
<b>Net Income</b>	<b>\$ 479,990</b>	<b>\$ 329,390</b>	<b>\$ 150,600</b>	<b>\$ 329,390</b>

No assurance is provided on these financial statements. See selected information.

**ITEM #12**



Blank

**DISTRIBUTION REQUEST NO.: #2-23/24**  
**ADMINISTRATION COSTS FUND**  
**(Account Number: 259424000)**

**DISTRIBUTION TOTAL: \$3,000.00**

\$6,100,000.00  
GRANADA SANITARY DISTRICT  
LIMITED OBLIGATION REFUNDING IMPROVEMENT BONDS 2003  
Reassessment & Refunding Project

DISTRIBUTION REQUEST  
For Payment of Administration Costs

The undersigned Treasurer of the Granada Sanitary District (the "District") hereby requests of the Fiscal Agent for the District the payment of Administration Costs for the items and in the manner and amount stated in the attached Schedule A, and in connection herewith hereby certifies that the payment requested is for the Administrative Costs, and that funds are available in the Administration Costs Fund (Account #259424000) to make such payment, and further states that all requirements for the payment of the amount to be disbursed pursuant hereto have been met.

Dated:  
August 17, 2023

---

Chuck Duffy, Finance Officer/Treasurer

**SCHEDULE "A"**

**DISTRIBUTION REQUEST NO.: #2-23/24**

**DATE: August 17, 2023**

**DISTRIBUTE FROM ACCOUNT #: 259424000**

**ACCOUNT NAME: Administration Costs Fund**

**DISTRIBUTION AMOUNT: \$ 3,000.00**

**PAYMENT INSTRUCTIONS:** Issue checks and mail as listed below.

<b>Payee</b>	<b>Mailing Address</b>	<b>Services Provided</b>	<b>Amount</b>
GCSD	P.O. Box 335, El Granada, CA 94018	OH Reim - August 2023	\$3,000.00
<b>TOTAL:</b>			<b>\$3,000.00</b>

**ITEM #13**

Blank

**GRANADA COMMUNITY SERVICES DISTRICT**

---

**AGENDA NOTICE**

---

There are no documents for this Agenda Item.



**ITEM #14**



Blank

**GRANADA COMMUNITY SERVICES DISTRICT**

---

**AGENDA NOTICE**

---

There are no documents for this Agenda Item.



**ITEM #15**

Blank

**GRANADA COMMUNITY SERVICES DISTRICT**

---

**AGENDA NOTICE**

---

There are no documents for this Agenda Item.



**ITEM #16**



Blank

GRANADA COMMUNITY SERVICES DISTRICT

---

# Administrative Staff Report

---

Period: July 15, 2023 to Aug 11, 2023  
To: Board of Directors  
From: Hope Atmore, Assistant General Manager  
Date: August 17, 2023

---

**PUBLIC RECORDS (ACT) REQUESTS** – There were no requests this period.

**APPLICATIONS RECEIVED**

There was one application received this period:

Date	Class	Owner/Agent	APN	Address	Sq. Ft.	Zone
07/06/23	1A	Lopez	047-191-440	1127 Columbus St, EG	6,500	R1/S-17
08/01/23	CL3	Solloway	047-288-030	1230 Columbus St EG	N/A	R1/S-17

Shaded items were previously reported.

**PERMITS ISSUED**

There were two permits issued this period:

Permit No.	Class	Date	Owner/Agent	APN	Address	Sq. ft.	Zone
3247	1A	07/26/23	Parnovskiy	047-221-060	417 Ave Del Oro, EG	5,000	R1/S-17
3249	1A	08/03/23	Carey	048-013-790	167 Cortez Ave, Miramar	7,446	R1/S94

**SEWER HOOK-UPS** - There were no new hook-ups this period.

**REPAIRS** - There were no lateral repairs this period.



**ITEM #17**

Blank

