



GRANADA COMMUNITY SERVICES DISTRICT

AGENDA **BOARD OF DIRECTORS** **SPECIAL MEETING at 6:30 p.m.**

Tuesday, August 3, 2021

DUE TO COVID-19 AND COUNTY REGULATIONS, THIS MEETING WILL BE HELD VIA TELECONFERENCE AS PERMITTED BY THE GOVERNOR'S EXECUTIVE ORDER N-08-21.

Members of the Public may participate via ZOOM online or by telephone:

[Join Zoom Meeting](#)

Phone one-tap: US: [+16699006833](tel:+16699006833), [99883485083#](tel:+19292056099) or [+19292056099](tel:+19292056099), [99883485083#](tel:+19292056099)

Meeting URL: <https://dudek.zoom.us/j/99883485083>

Join by Telephone

Dial:

US: +1 669 900 6833 or +1 929 205 6099

Meeting ID: 998 8348 5083

CALL SPECIAL MEETING TO ORDER AT 6:30 p.m.

ROLL CALL

Directors:	President:	Matthew Clark
	Vice-President:	Eric Suchomel
	Director:	Barbara Dye
	Director:	Nancy Marsh
	Director:	David Seaton
Staff:	General Manager:	Chuck Duffy
	Assistant Manager:	Delia Comito
	District Counsel:	Bill Parkin

The Board has the right to take action on any of the items listed on the Agenda. The Board reserves the right to change the order of the agenda items, to postpone agenda items to a later date, or to table items indefinitely.

GENERAL PUBLIC PARTICIPATION

Public members may comment on matters under the jurisdiction of the District that are not on the agenda. Comments are limited to 3 minutes. See the instructions above to comment via ZOOM (online) or by telephone.

ACTION AGENDA

1. Consideration of Operations Issues, BOD Loading, and Process Study at the Sewer Authority Mid-Coastside Wastewater Treatment Plant.

Recommendation: To be made by the Board.

ADJOURN TO CLOSED SESSION

2. Conference with Real Property Negotiator (Government Code Section 54956.8). Property: 480 Avenue Alhambra, El Granada, California.

District's Negotiator: Chuck Duffy

Negotiating parties: Candise D'Acquisto (Owner) Picasso Preschool and Granada Community Services District.

Under negotiation: Instruction to negotiator regarding price and terms of lease.

RECONVENE TO OPEN SESSION

Report any reportable action taken in Closed Session.

ADJOURN SPECIAL MEETING

At the conclusion of the July 22, 2021 Meeting:

Last Ordinance adopted: No. 174

Last Resolution adopted: No. 2021-005

This meeting is accessible to people with disabilities. If you have a disability and require special assistance related to participating in this teleconference meeting, please contact the District at least two working days in advance of the meeting at (650) 726-7093 or via email at dcomito@granada.ca.gov.

Except for records exempt from disclosure under section 6254 of the Public Records Act, all materials distributed for the discussion or consideration of items on the Agenda are disclosable to the public upon request, and shall be made available without delay or at the time of distribution to the Board. Please contact Delia Comito at (650) 726-7093 to request copies of Agenda materials.

SAM Board Workshop: Optimization Alternatives

July 26, 2021

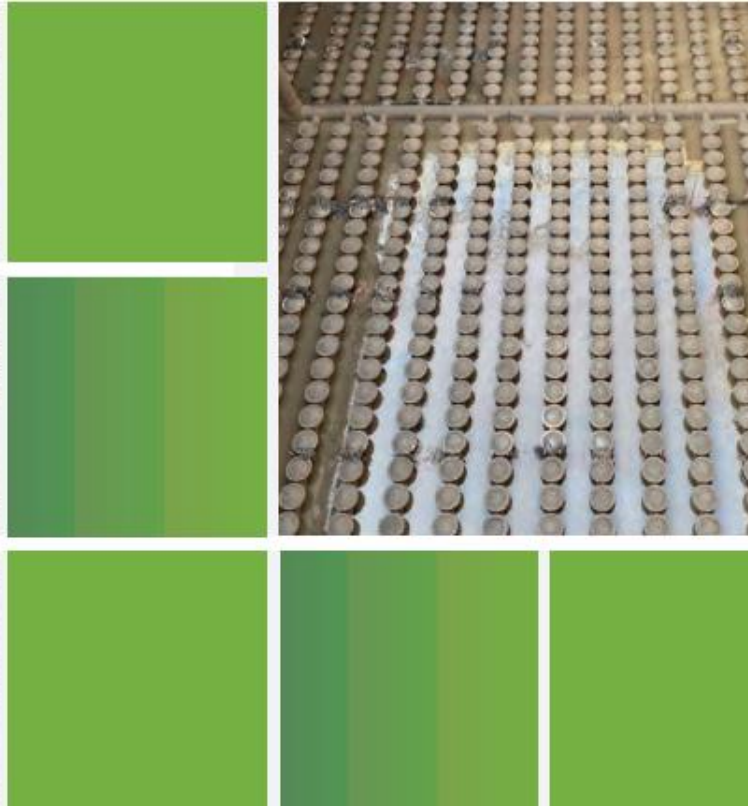

Agenda

- Workshop Objectives
- Optimization Alternatives Results
- Recommendations and Direction
- Next Steps / Schedule



Workshop Objectives

Workshop Objectives

- Review Optimization Alternatives
- Review Alternative Costs
- Discuss Recommendations



Plant Optimization Options

Alternatives Capacity Discussion

- The presented alternatives are not intended to upgrade all of the aeration tanks as part of the initial Project; additional upgrades would be required to reach the original design loading

Cost Estimating Assumptions

- Costs shown are marked up to represent construction costs, or the cost we expect a contractor to bid at
- Actual project costs (i.e. capital costs) may be **30-35%** higher (see next slide)
- Class 5 estimate, with an error band of -50% to +100%
- All costs are in 2021 dollars and need to be escalated to the planned year of construction

Example Capital Cost Markups (in addition to construction costs)

Project Element	Percentage
Project Administration	5%
Planning/Environmental	10%
Design	10%
Construction Management	10%
Total	35%

Alternative 1: Use Aeration Basins 3 and 4

Typical Operation: Use AT 3 and 4 in parallel the short term, and use tanks 1 and/or 2 for redundancy

Scope:

- Install fine bubble diffusers in Basin 4
- Install aeration piping/valving in Basin 4
- Install spray water piping in Basin 4
- Replace weir gates in Basins 1 and 2
- Install DO probe in Basin 4

Class 5 OPCC: \$565,000 (- 50 %, + 100 %)

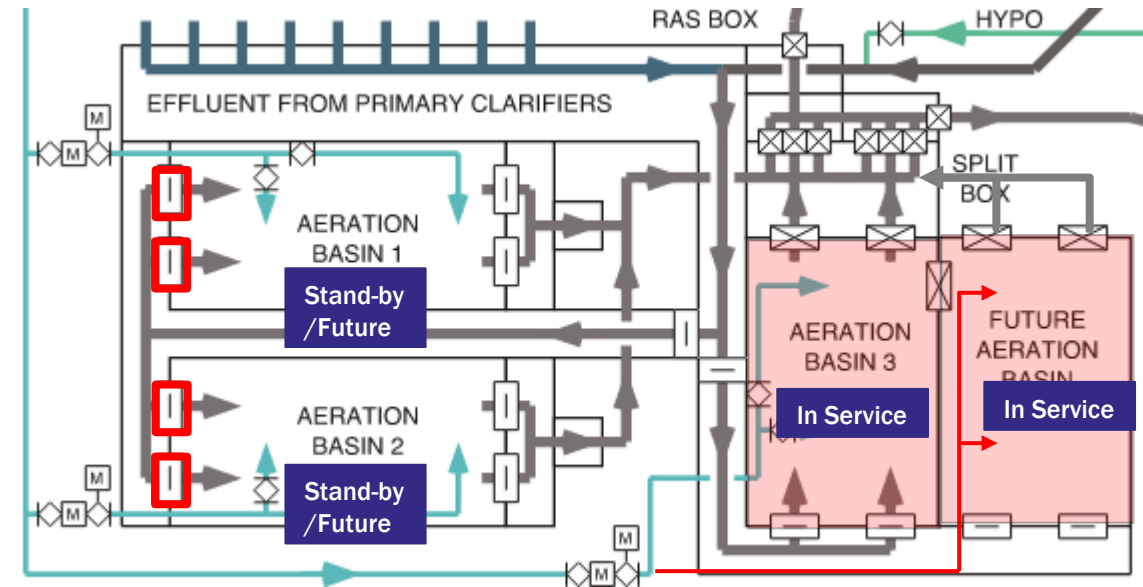

Alternative 1 Cost Breakdown

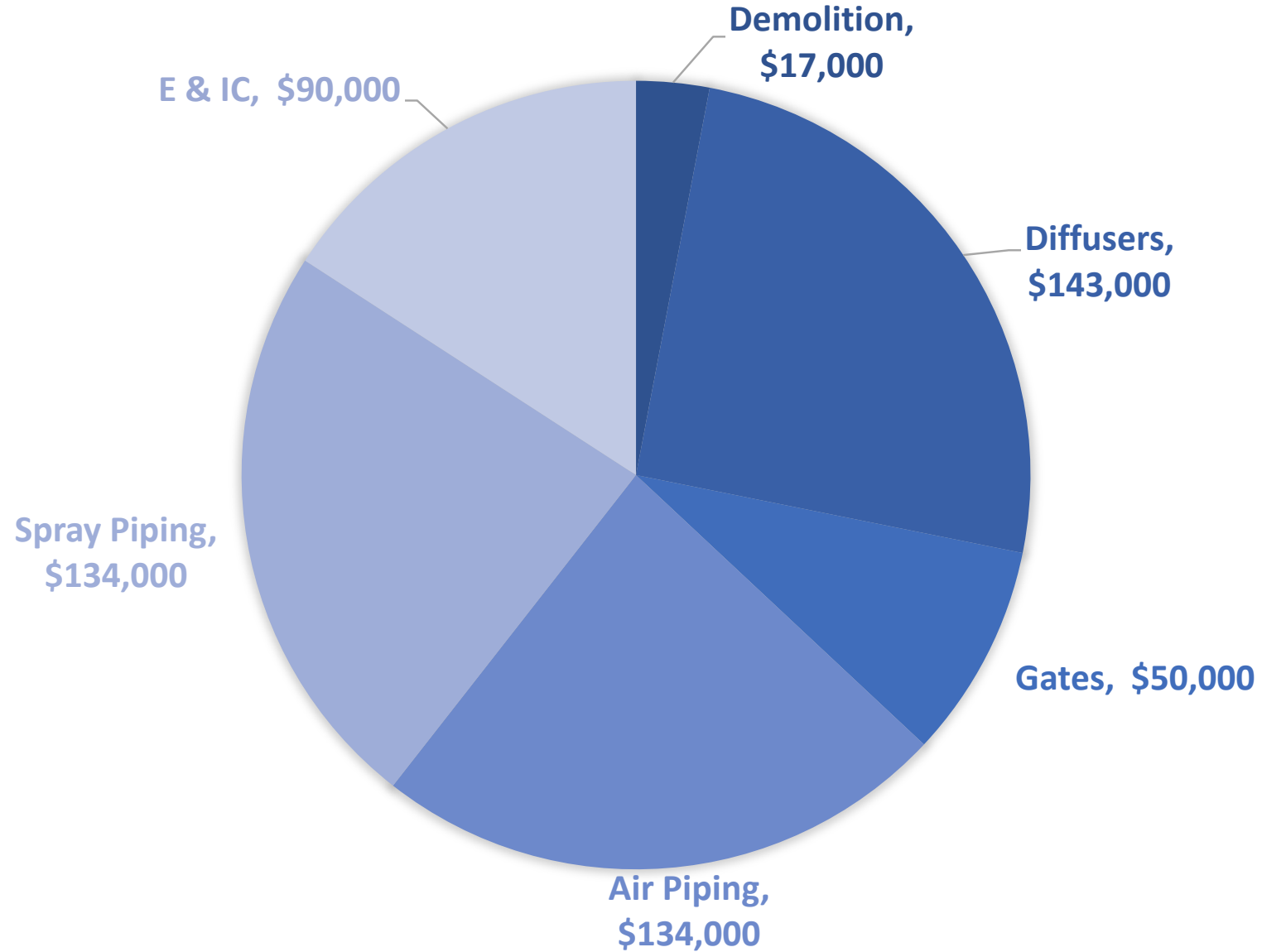

Alternative 1 Pros/Cons

Pros	Cons
Provides the most redundancy	Need additional utility piping, air header piping and weir gates in addition to the fine bubble diffusers for outfitting Aeration Basin 4
Can use Aeration Basins 1 and 2 when performing maintenance on Aeration Basin 3 or 4	
More efficient oxygen transfer in Aeration Basin 3 and 4 with new fine bubble diffusers (lower energy)	
Can utilize Basins 1 and 2 in the future if needed to accommodate additional growth	

Alternative 2: Use Aeration Basins 1, 2, and 3

Typical Operation: Use AT 1, 2, and 3 in parallel

Scope:

- Remove the existing coarse bubble diffusers in Basin 1 and 2
- Install new fine bubble diffusers in Basins 1 and 2
- Replace weir gates in Basins 1 and 2
- Construct new baffle walls in Basins 1 and 2 (for better hydraulics)

Class 5 OPCC: \$683,000 (- 50 %, + 100 %)

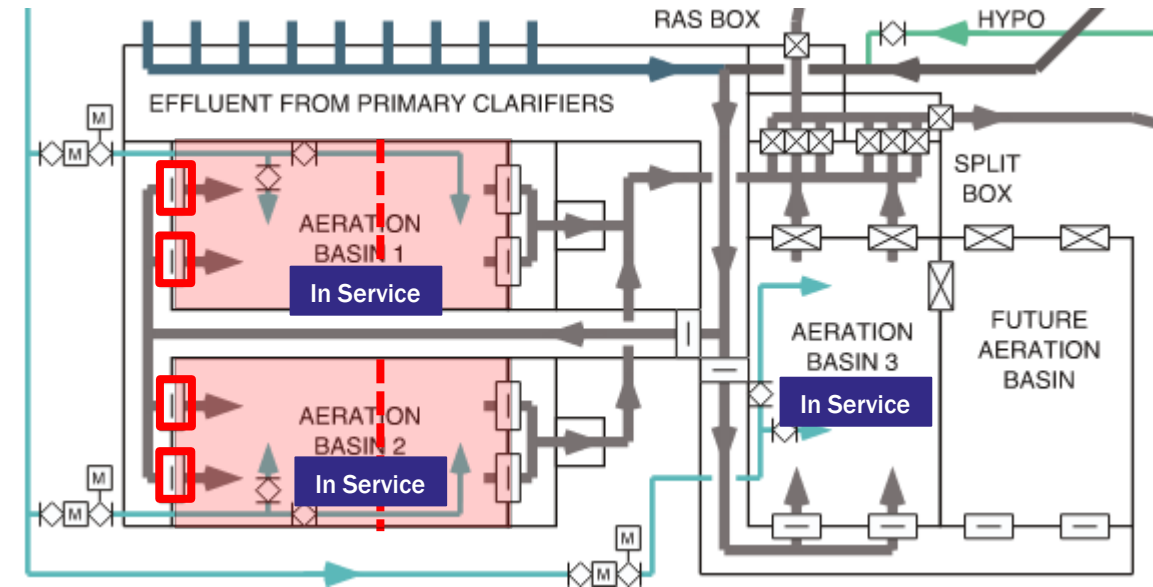

Alternative 2 Cost Breakdown

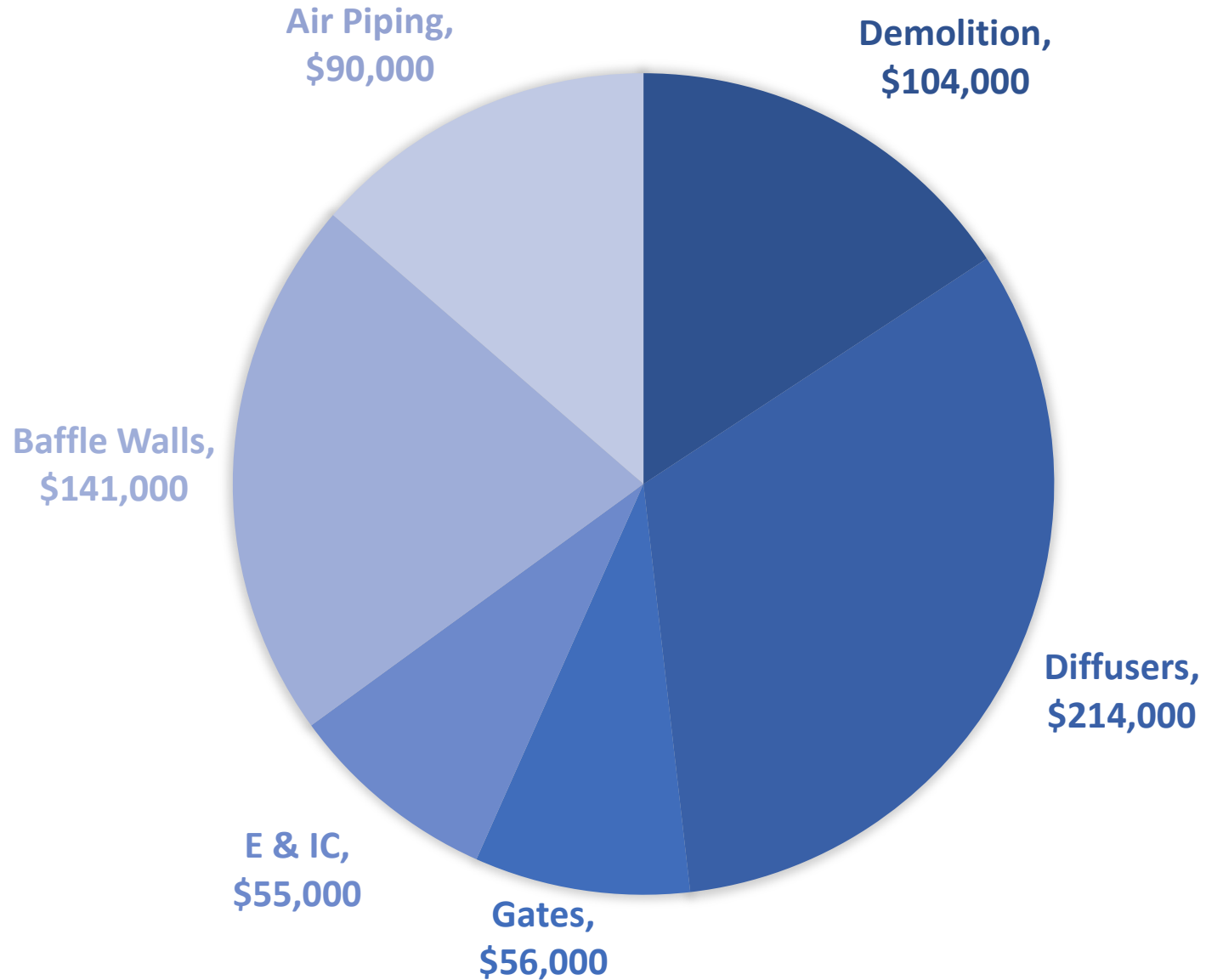

Alternative 2 Pros/Cons

Pros	Cons
Does not require installing new process piping to connect to Basin 4	Completely strand assets in basin 4
Significant increase in capacity, from only one Basin available to 3 basins available	Lower Redundancy than Alternative 1
Repurposes existing tanks for better performance	Older basins have more uncertainties associated with condition

Alternative 3: Operate in series with biological selector

Typical Operation: Operate Tank 2 and 3 in series.
Need Tank 4 when maintaining Tank 3.

Scope:

- Fully upgrade Basin 4 (see Alt. 1 for details)
- Install new fine bubble diffusers in Basins 1/2
- Construct a new baffle walls in Basins 1/2
- Install submersible mixers in Basins 1/2
- Install coarse bubble diffusers in the Basin 1 Channel
- Infill openings in the concrete divider wall in the Basin 1 Channel
- Install stainless steel stop plates in the basin channels

Class 5 OPCC: \$1,050,000 (- 50 %, + 100 %)

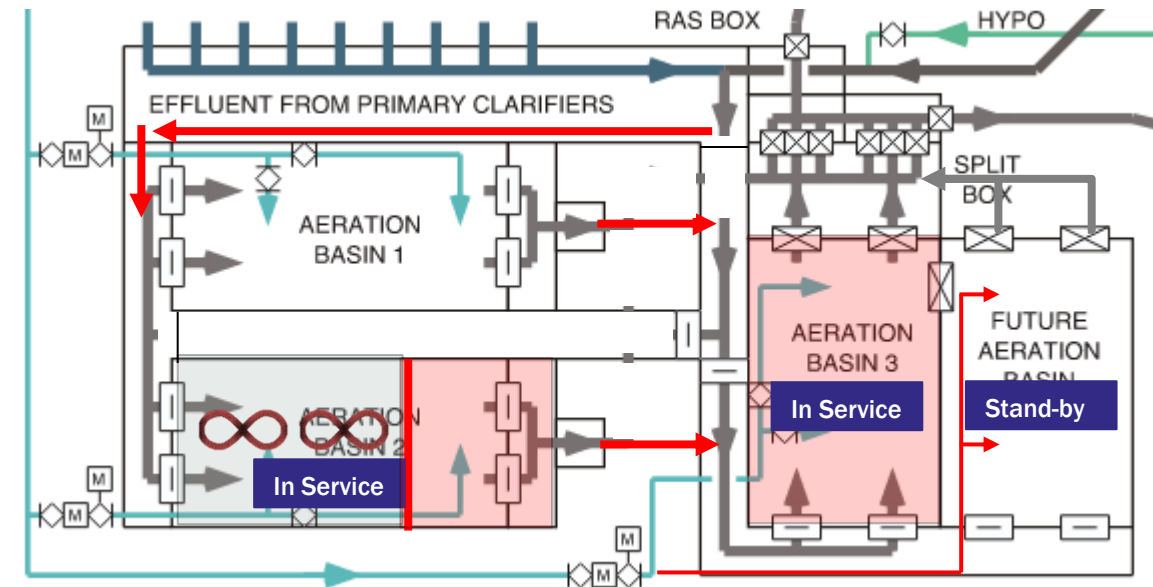

Alternative 3 Cost Breakdown

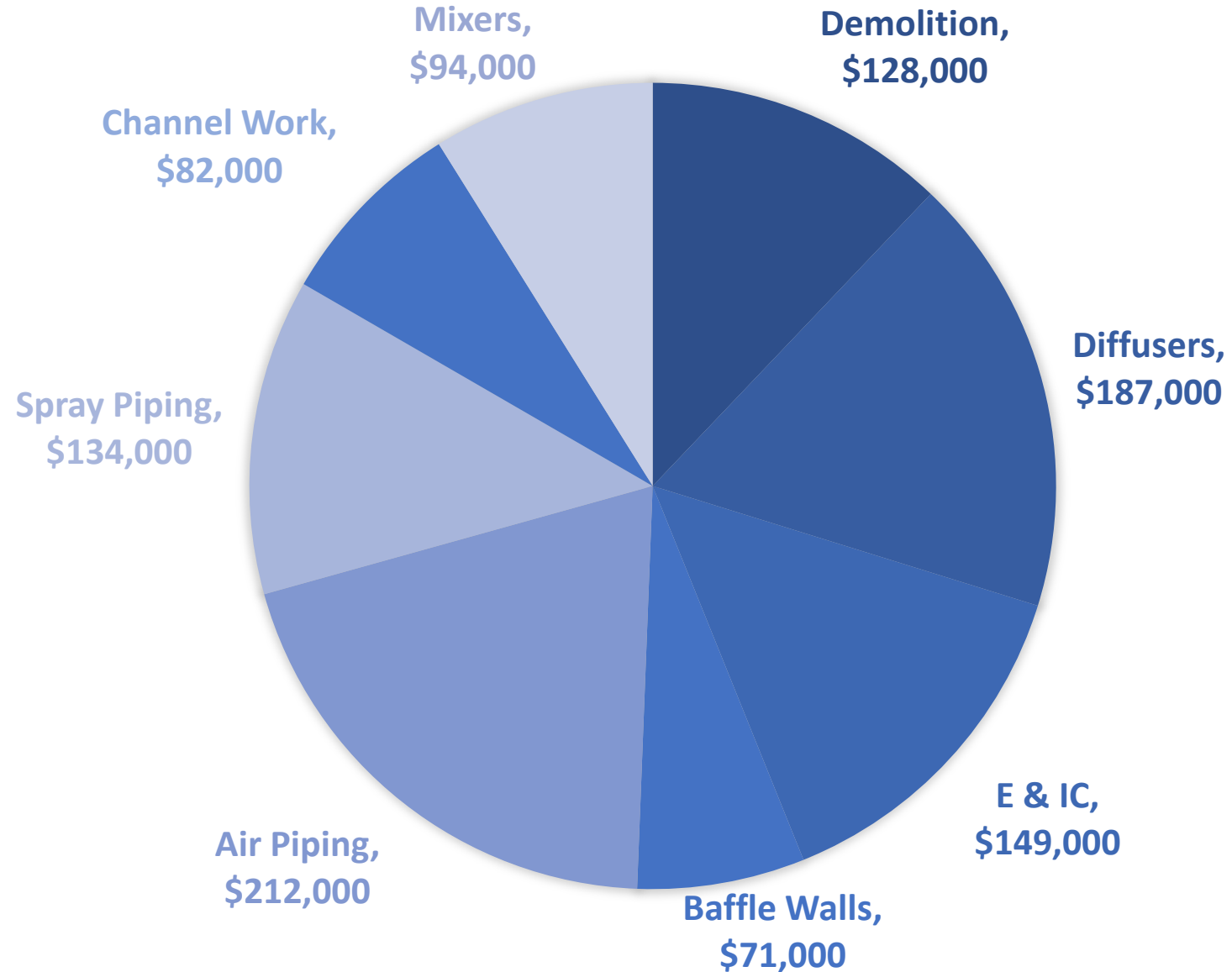

Alternative 3 Pros/Cons

Pros	Cons
Highest overall capacity, if all tanks are built out	Highest cost project
Better settleability, strong process resiliency	High probability of struvite precipitation issues, which would add additional O&M costs
	Complex construction to change flow routing through aeration tank system
	New process to SAM operations team

Equalization in Basin 1

Typical Operation: Aeration Basin 1 cannot be used for treatment, only PE EQ

Scope:

- Install submersible pump
- Install 8" pipe with magnetic flow meter

Class 5 OPCC: \$243,000 (- 50 %, + 100 %)

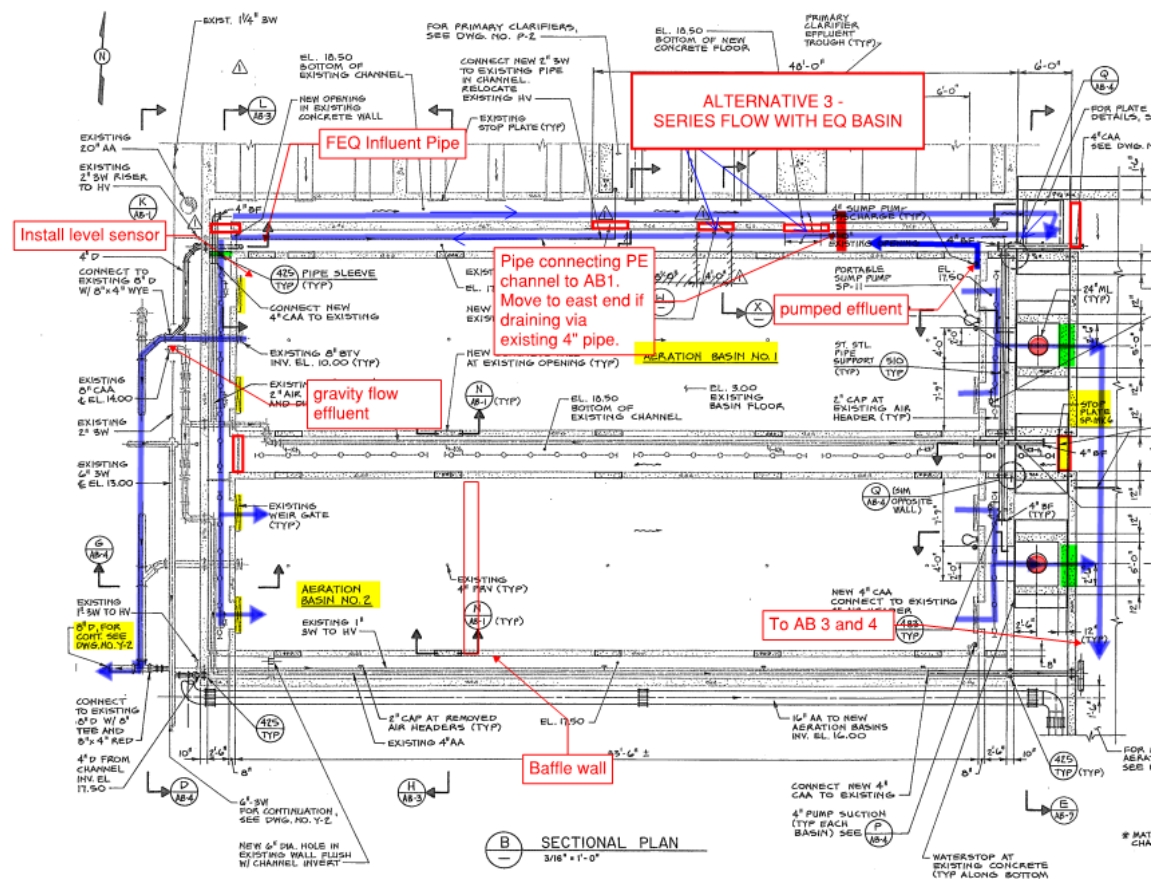

Zoom on Details of Equalization Conversion

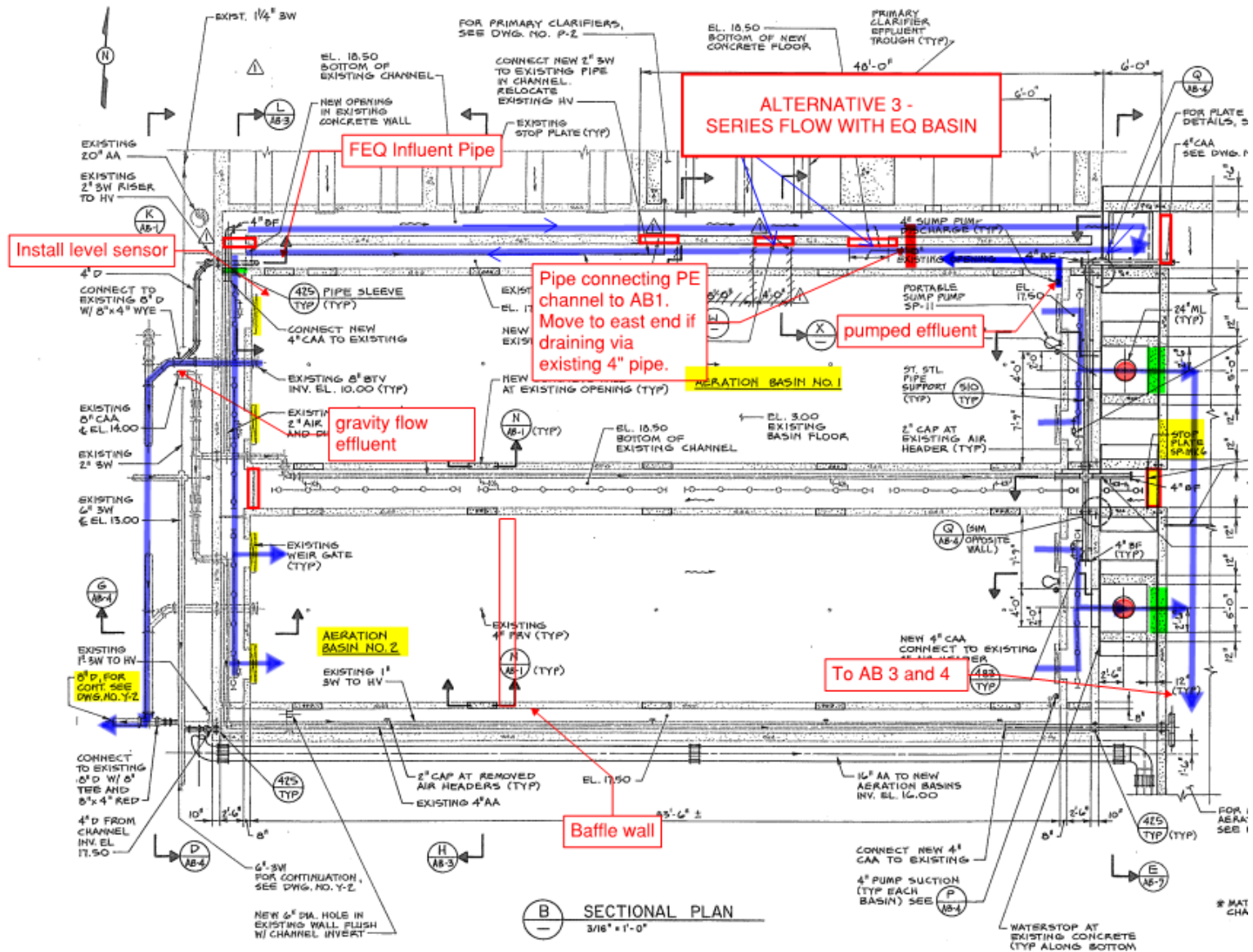

Capacity of Alternatives Based on Design PDWWF = 9 mgd

Capacity Based on Current BOD Concentration of 340 mg/L

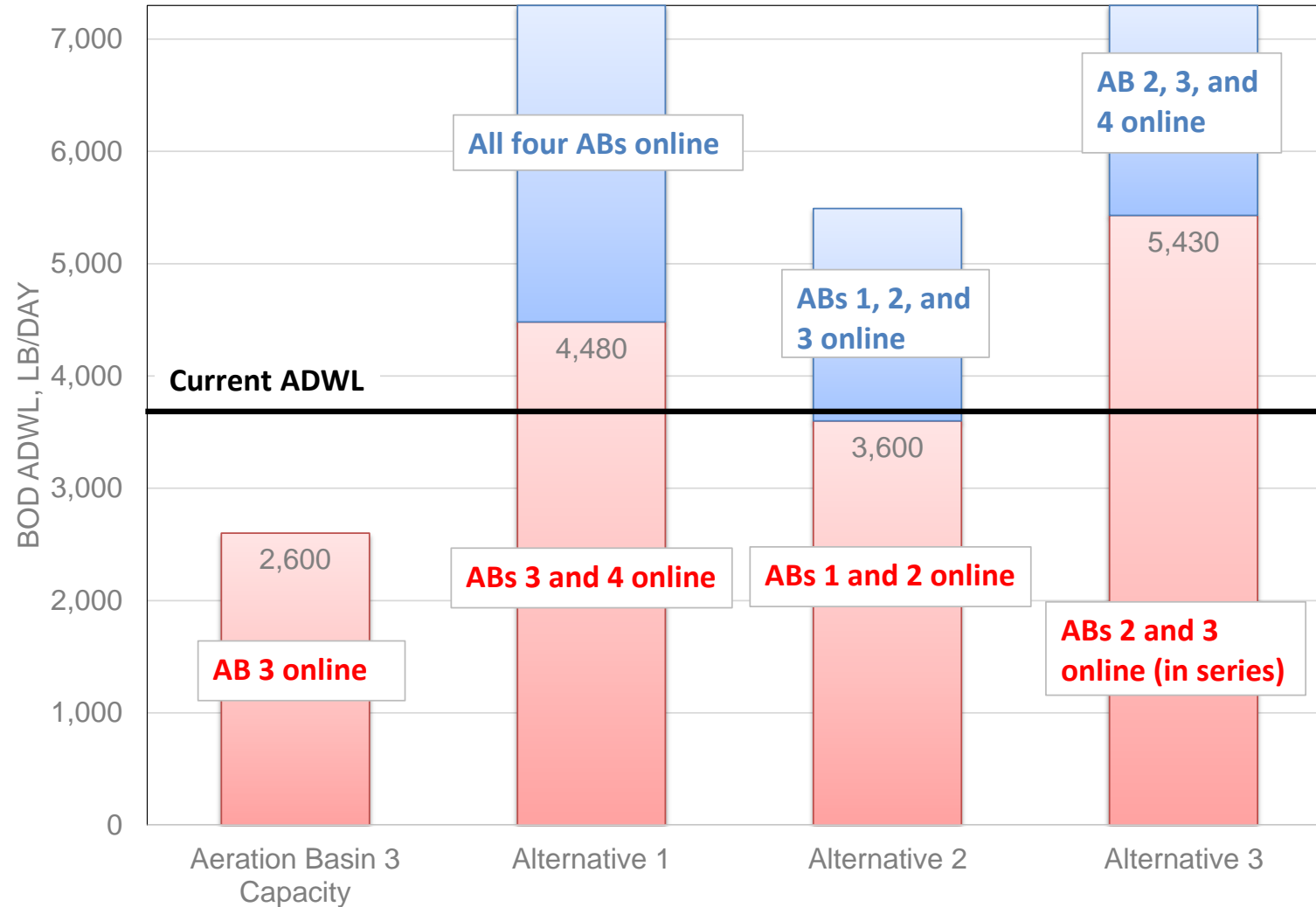

Summary of Construction Costs

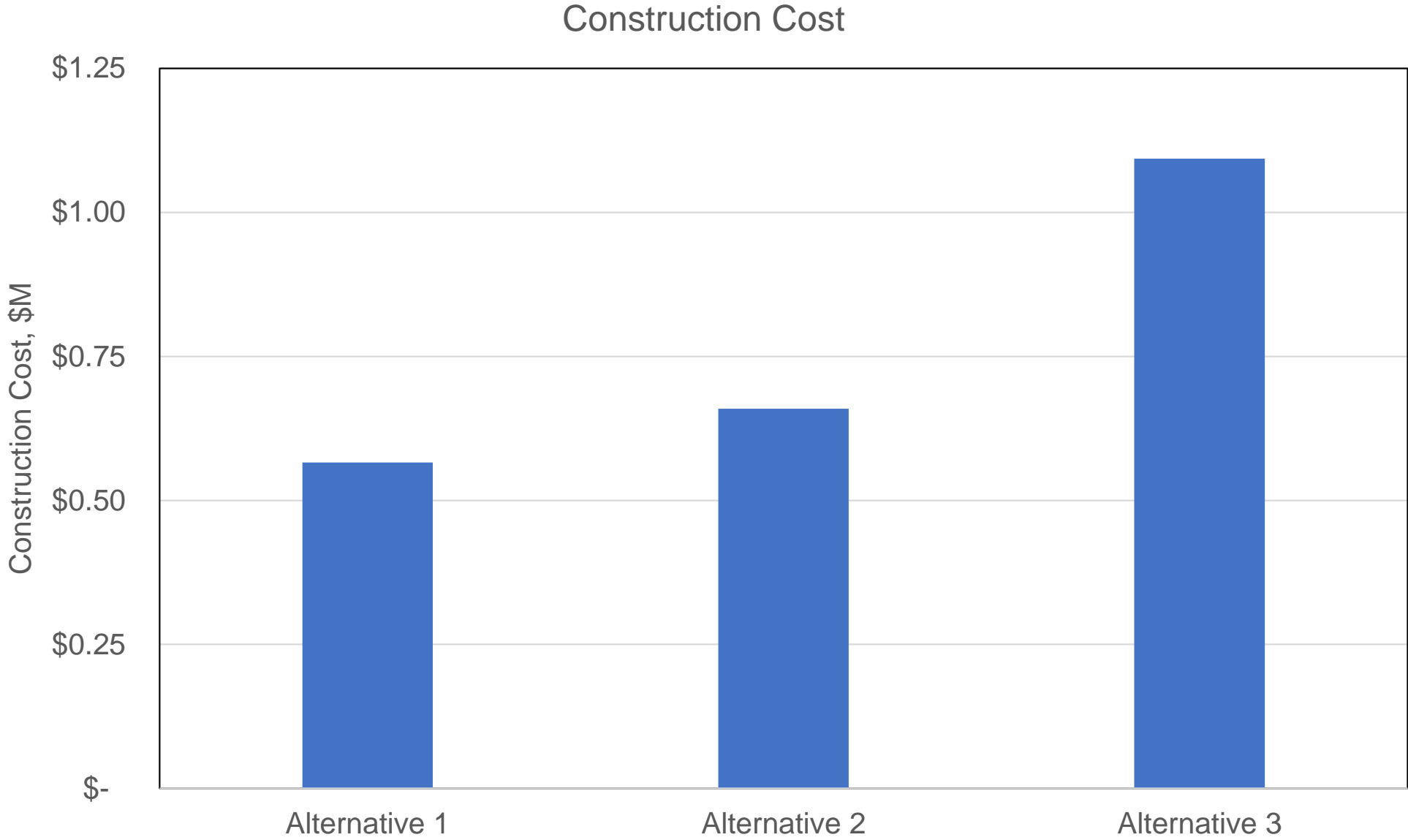

Summary of Alternatives and Associated Risks

Alternatives Analysis Summary				
	Current Configuration	Alternative 1	Alternative 2	Alternative 3
Treatment Capacity to meet current loading	No	Yes	Yes	Yes
Redundancy	No	Yes	No	No
Cost	N/A	Low	Medium	High
Risk of construction cost increase	N/A	Low	High	High
Probability risk of violation	High	Low	Medium	Low
Construction Risk	N/A	Low	High	High
Operational complexity and risk	Low	Low	Low	High
Maintenance risk	High	Low	High	High

Note: The current configuration is assumed to be either Aeration Basin 3 in service or Aeration Basins 1 and 2 in service

Recommendations

- Alternative 3 has high costs, is complex, and will result in other O&M issues at SAM. **BC does not recommend implementing Alternative 3 at this time.** Re-consider if significant growth is experienced in the area and significantly higher capacity is required (population and/or industry)
- **BC recommends pursuing Alternative 1.** Both put SAM in a good position to address capacity limitations both in the short term and with additional expansion, to reach design capacity loading in the long term (if needed).
- Equalization costs were provided but operating an aeration tank as EQ does not improve capacity and **is not recommended for implementation at this time.**



Next Steps

Now What?

- SAM to provide comments to draft report
- BC to finalize report
- Collections System Source Identification/Monitoring

QUESTIONS?

